



# Universal Controller

Universal electronic controller



UNIVERSAL  
controller



## USER MANUAL

→ **LEGGI E CONSERVA  
QUESTE ISTRUZIONI** ←  
**READ AND SAVE  
THESE INSTRUCTIONS**



**CAREFULLY READ THE**

TEXT

### Universal Controller

Up to date version available on  
[www.ksa.carel.com](http://www.ksa.carel.com)

## GENERAL WARNINGS



CAREL bases the development of its products on decades of experience in HVAC, on continuous investments in technological innovations to products, procedures and strict quality processes with in-circuit and functional testing on 100% of its products, and on the most innovative production technology available on the market. CAREL and its subsidiaries/affiliates nonetheless cannot guarantee that all the aspects of the product and the software included with the product respond to the requirements of the final application, despite the product being developed according to start-of-the-art techniques. The customer (manufacturer, developer or installer of the final equipment) accepts all liability and risk relating to the configuration of the product in order to reach the expected results in relation to the specific final installation and/or equipment. CAREL may, based on specific agreements, act as a consultant for the successful commissioning of the final unit/application, however in no case does it accept liability for the correct operation of the final equipment/system. The CAREL product is a state-of-the-art product, whose operation is specified in the technical documentation supplied with the product or can be downloaded, even prior to purchase, from the website [www.carel.com](http://www.carel.com). Each CAREL product, in relation to its advanced level of technology, requires setup/configuration/programming/commissioning to be able to operate in the best possible way for the specific application. Failure to complete such operations, which are required/indicated in the user manual, may cause the final product to malfunction; CAREL accepts no liability in such cases. Only qualified personnel may install or carry out technical service on the product. The customer must only use the product in the manner described in the documentation relating to the product. In addition to observing any further warnings described in this manual, the following warnings must be heeded for all CAREL products:

- prevent the electronic circuits from getting wet. Rain, humidity and all types of liquids or condensate contain corrosive minerals that may damage the electronic circuits. In any case, the product should be used or stored in environments that comply with the temperature and humidity limits specified in the manual.
- do not install the device in particularly hot environments. Too high temperatures may reduce the life of electronic devices, damage them and deform or melt the plastic parts. In any case, the product should be used or stored in environments that comply with the temperature and humidity limits specified in the manual.
- do not attempt to open the device in any way other than described in the manual.
- do not drop, hit or shake the device, as the internal circuits and mechanisms may be irreparably damaged;
- do not use corrosive chemicals, solvents or aggressive detergents to clean the device.
- do not use the product for applications other than those specified in the technical manual.

All of the above suggestions likewise apply to the controllers, serial cards, programming keys or any other accessory in the CAREL product portfolio. CAREL adopts a policy of continual development. Consequently, CAREL reserves the right to make changes and improvements to any product described in this document without prior warning. The technical specifications shown in the manual may be changed without prior warning. The liability of CAREL in relation to its products is specified in the CAREL general contract conditions, available on the website [www.carel.com](http://www.carel.com) and/or by specific agreements with customers; specifically, to the extent where allowed by applicable legislation, in no case will CAREL, its employees or subsidiaries/affiliates be liable for any lost earnings or sales, losses of data and information, costs of replacement goods or services, damage to things or people, downtime or any direct, indirect, incidental, actual, punitive, exemplary, special or consequential damage of any kind whatsoever, whether contractual, extra-contractual or due to negligence, or any other liabilities deriving from the installation, use or impossibility to use the product, even if CAREL or its subsidiaries/affiliates are warned of the possibility of such damage.

## DISPOSAL

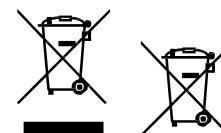

Fig. 1 Fig. 2

### INFORMATION FOR USERS ON THE CORRECT HANDLING OF WASTE ELECTRICAL AND ELECTRONIC EQUIPMENT (WEEE)

The product is made up of metal parts and plastic parts. In reference to European Union directive 2002/96/EC issued on 27 January 2003 and related national legislation, please note that:

- WEEE cannot be disposed of as municipal waste and such waste must be collected and disposed of separately;
- the public or private waste collection systems defined by local legislation must be used. In addition, the equipment can be returned to the distributor at the end of its working life when buying new equipment;
- the equipment may contain hazardous substances: the improper use or incorrect disposal of such may have negative effects on human health and on the environment;
- the symbol (crossed-out wheeled bin) shown on the product or on the packaging and on the technical leaflet indicates that the equipment has been introduced onto the market after 13 August 2005 and that it must be disposed of separately;
- in the event of illegal disposal of electrical and electronic waste, the penalties are specified by local waste disposal legislation.

Warranty on materials: 2 years (from production date, excluding consumables).

Approval: the quality and safety of CAREL S.P.A. products are guaranteed by the ISO 9001 certified design and production system.

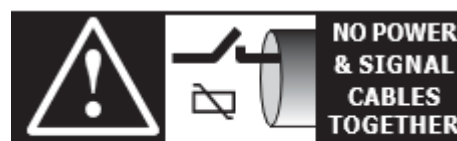

### READ CAREFULLY IN THE TEXT!

Separate as much as possible the probe and digital input cables from cables to inductive loads and power cables, so as to avoid possible electromagnetic disturbance. Never run power cables (including the electrical panel cables) and signal cables in the same conduits.

Key to the symbols:

Caution: to bring critical issues to the attention of those using the product. Notice: to focus attention on important topics; in particular the practical application of the various product functions.

Notice: to focus attention on important topics; in particular the practical application of the various product functions.

Caution: this product is to be integrated and/or incorporated into the final apparatus or equipment. Verification of conformity to the laws and technical standards in force in the country where the final apparatus or equipment will be operated is the manufacturer's responsibility. Before delivering the product, Carel has already completed the checks and tests required by the relevant European directives and harmonised standards, using a typical test setup, which however cannot be considered as representing all possible conditions of the final installation.

# Contents

|   |           |
|---|-----------|
| <b>1. INTRODUCTION.....</b>   | <b>5</b>  |
| 1.1 Main functions .....  | 5         |
| 1.2 Models .....  | 6         |
| 1.3 Accessories .....   | 6         |
| 1.3.1 USB/RS485 converter (CVSTDUMOR0).....                               | 6         |
| 1.3.2 Connector kit.....  | 6         |
| <b>2. INSTALLATION .....</b>  | <b>7</b>  |
| 2.1 Warnings .....  | 7         |
| 2.2 Panel version .....   | 7         |
| 2.2.1 Dimensions (mm).....  | 7         |
| 2.2.2 Mounting.....   | 7         |
| 2.2.3 Removal.....  | 8         |
| 2.3 DIN rain version .....  | 8         |
| 2.3.1 Dimensions (mm).....  | 8         |
| 2.3.2 Removal.....  | 8         |
| 2.4 Electrical installation .....   | 9         |
| 2.4.1 Description of the terminals.....                                   | 10        |
| 2.5 Probe / digital input connection.....                                 | 11        |
| 2.6 Serial port connections .....   | 12        |
| 2.7 Positioning inside the panel .....                                    | 12        |
| <b>3. USER INTERFACE .....</b>  | <b>13</b> |
| 3.1 Introduction.....   | 13        |
| 3.2 User terminal .....   | 13        |
| 3.2.1 Keypad.....   | 13        |
| 3.2.2 Icons.....  | 13        |
| 3.3 Display main page view .....  | 14        |
| 3.3.1 Main unit values.....   | 15        |
| 3.3.2 Direct access parameters .....                                      | 17        |
| 3.3.3 Access the programming menu.....                                    | 18        |
| 3.3.4 Programming menu.....   | 19        |
| <b>4. COMMISSIONING .....</b>   | <b>20</b> |
| 4.1 Applica app.....  | 20        |
| 4.1.1 Connection to the controller.....                                   | 20        |
| 4.2 Configuration procedure .....   | 21        |
| 4.2.1 Main sections.....  | 21        |
| 4.2.2 Parameter list .....  | 24        |
| 4.2.3 Create a unit configuration.....                                    | 25        |
| 4.2.4 FW update.....  | 26        |
| 4.3 Applica Desktop.....  | 27        |
| 4.3.1 Connection to the controller.....                                   | 27        |
| 4.4 Setup procedure with Applica Desktop .....                            | 28        |
| 4.4.1 Create a unit configuration.....                                    | 28        |
| 4.4.2 Date and time setting.....  | 29        |
| 4.4.3 Parameter list .....  | 30        |
| 4.4.4 FW update.....  | 30        |
| <b>5. FUNCTIONS.....</b>  | <b>31</b> |
| 5.1 Standard operating modes .....  | 31        |
| 5.1.1 Mode 1: Direct (B000=1).....  | 32        |
| 5.1.2 Mode 2: Reverse (B000=2).....                                       | 33        |
| 5.1.3 Mode 3: Neutral zone (B000=3).....                                  | 34        |
| 5.1.4 Mode 6: Direct/reverse changeover from DI1 (B000=6).....            | 35        |
| 5.1.5 Mode 7: Set point and differential from DI1 (Direct) (B000=7).....  | 36        |
| 5.1.6 Mode 8: Set point and differential from DI1 (Reverse) (B000=8)..... | 37        |
| 5.1.7 Mode 9: Direct/reverse with two set points (B000=9).....            | 38        |
| 5.1.8 Mode 10: 3-position valve (B000=10).....                            | 39        |
| 5.2 Operating modes with probe 2 (Prb2).....                              | 41        |
| 5.2.1 Differential operation (Prb1-Prb2) (B012=1).....                    | 41        |
| 5.2.2 Enable regulation based on absolute set point (B012=5).....         | 42        |
| 5.2.3 Enable regulation based on set point differential (B012=6).....     | 42        |
| 5.2.4 Independent operation (circuit 1 + circuit 2) (B012=7).....         | 43        |
| 5.2.5 Control on the higher probe value (B012=8).....                     | 44        |
| 5.2.6 Control on the lower probe value (B012=9).....                      | 44        |
| 5.2.7 Set point on probe 2 (B012=10).....                                 | 45        |
| 5.2.8 Automatic summer/winter changeover from probe 2 (B012=11).....      | 45        |

|   |           |
|---|-----------|
| 5.3 Probe 3 functions (B036)                          | 46        |
| 5.3.1 Summer compensation (B036=1)                    | 46        |
| 5.3.2 Winter compensation (B036=2)                    | 47        |
| 5.3.3 Summer/winter compensation (B036=3)             | 48        |
| 5.3.4 Read-only (B036=4)                              | 48        |
| 5.4 Special operation (B000=0)                        | 49        |
| 5.5 Scheduler   | 50        |
| 5.6 Soft start  | 51        |
| 5.7 Output rotation                                   | 51        |
| <b>6. PARAMETER TABLE</b>                             | <b>52</b> |
| 6.1 Main page (press DOWN briefly)                    | 52        |
| 6.2 Main page (press PRG briefly)                     | 53        |
| 6.3 Input/output configuration                        | 53        |
| 6.4 Control configuration                             | 55        |
| 6.4.1 PID parameter table (B004=1)                    | 56        |
| 6.4.2 Special parameter table (B000=0)                | 58        |
| 6.5 Alarm configuration                               | 61        |
| 6.6 Settings  | 61        |
| 6.7 Clock   | 62        |
| 6.8 Scheduler   | 62        |
| <b>7. SUPERVISION</b>                                 | <b>64</b> |
| 7.1 Unit on/off management from BMS                   | 64        |
| 7.2 Supervisor model for Boss and PlantVisorPRO range | 64        |
| <b>8. ALARMS AND SIGNALS</b>                          | <b>65</b> |
| 8.1 Types of alarms                                   | 65        |
| 8.2 Override regulation outputs                       | 65        |
| 8.3 Alarm list  | 66        |
| <b>9. TECHNICAL SPECIFICATIONS</b>                    | <b>67</b> |
| 9.1 Connector/cable table                             | 68        |
| <b>10. RELEASE NOTES</b>                              | <b>69</b> |

# 1. INTRODUCTION

The Universal Controller is a configurable device for regulation of the main physical measurements (temperature, pressure, humidity) in air conditioning, refrigeration and heating units. ON/OFF, proportional, and PID regulation can be managed.

If a second probe is connected, differential regulation can be managed with reference to the main probe, or a second independent regulation function can be activated with dedicated set point, differential and outputs.

If a third probe is connected, summer/winter compensation can be managed for adjusting the current set point.

The integrated clock and scheduler can be used to set when the unit should change the regulation set point, based on the set comfort and economy modes, or when to switch off.

The user terminal features wireless connectivity via Bluetooth with mobile devices and is available on both the panel and DIN rail models. CAREL's "APPLICA" app, available on Google Play for the Android operating system and App Store for Apple iOS, makes it easier to configure parameters and commission the unit in the field.

## 1.1 Main functions

| Ref.                               | Description   |
|------------------------------------|---|
| <b>Main features</b>               | 1 analogue input:<br>NTC, PT1000, 0-10 VDC, 0-5 VDC ratiometric, 0-20 mA, 4-20 mA           |
|                                    | 2 analogue inputs: NTC, 0-5 VDC ratiometric, 0-20 mA, 4-20 mA                               |
|                                    | 2 voltage-free contact inputs   |
|                                    | 2 x 0-10 V analogue outputs   |
|                                    | 5 x 5 A digital outputs   |
| <b>Hardware</b>                    | Panel mounting model  |
|                                    | DIN rail model  |
| <b>User interface</b>              | 2-row, 7-segment LED display for panel and DIN rail models                                  |
|                                    | Communication with APPLICA app (BTLE compatible) for mobile devices                         |
| <b>Control</b>                     | 1 main regulation loop, ON/OFF, proportional, PID referring to probe 1                      |
|                                    | 1 loop for additional logic or second independent circuit referring to probe 2              |
|                                    | 1 loop for set point compensation logic referring to probe 3                                |
|                                    | Special mode for setting independent regulation for individual digital and analogue outputs |
| <b>Programming with time bands</b> | RTC with date/time retention after power off for 72 h                                       |
|                                    | 3 daily programs, 4 time bands per program  |
|                                    | Off, Comfort, Economy mode  |
| <b>Alarms</b>                      | Management of vacation periods and special days   |
|                                    | Management of automatic and manual reset according to alarm severity                        |
| <b>Connectivity/supervision</b>    | Alarm log (up to 20 events): alarm and reset date and time recorded                         |
|                                    | RS485 serial port   |
| <b>Modbus RTU</b>                  | Serial address from 1 to 247  |
|                                    | Baud rate up to 375000 bit/s  |
|                                    | Parity (none, even, odd) and stop bits (1 or 2)   |
|                                    | Fixed 8 bit data bits   |

## 1.2 Models



DIN rail model

| Part number | Description |
|-------------|-------------|
|-------------|-------------|

|               |                |
|---------------|----------------|
| U20R00UC00200 | Panel model    |
| U20R00UC00250 | DIN rail model |



Panel model

## 1.3 Accessories

### 1.3.1 USB/RS485 converter (CVSTDUMOR0)



Electronic device for interfacing an RS485 network to a personal computer via the USB port.  
See technical leaflet +050000590.

### 1.3.2 Connector kit

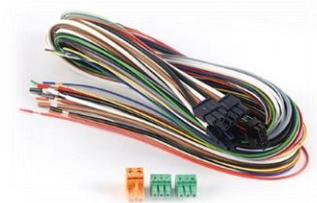

| Part number | Description |
|-------------|-------------|
|-------------|-------------|

|            |   |
|------------|---|
| UCHCOND010 | CONN. AND CABLE KIT UCHILLER DIN MOLEX/FREE 100CM   |
| UCHCOND030 | CONN. AND CABLE KIT UCHILLER DIN MOLEX/FREE 300CM   |
| UCHCONP010 | CONN. AND CABLE KIT UCHILLER PANEL MOLEX/FREE 100CM |
| UCHCONP030 | CONN. AND CABLE KIT UCHILLER PANEL MOLEX/FREE 300CM |

# 2. INSTALLATION

## 2.1 Warnings

- ⚠ Caution: avoid installing the controller in environments with the following characteristics:
- temperature and humidity that do not comply with the ambient operating conditions (see "Technical specifications");
  - strong vibrations or knocks;
  - exposure to water sprays or condensate;
  - exposure to aggressive and polluting atmospheres (e.g.: sulphur and ammonia gases, saline mist, smoke) which may cause corrosion and/or oxidation;
  - strong magnetic and/or radio frequency interference (thus avoid installation near transmitting antennae);
  - exposure to direct sunlight and the elements in general;
  - wide and rapid fluctuations in ambient temperature;
  - exposure to direct sunlight, the weather in general and dust (formation of corrosive patina with possible oxidation and reduction of insulation).

## 2.2 Panel version

### 2.2.1 Dimensions (mm)

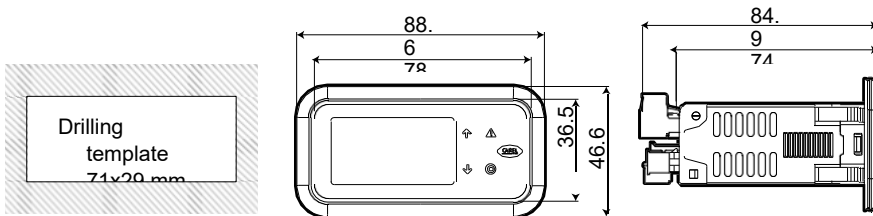

### 2.2.2 Mounting

⚠ Caution: before carrying out any maintenance, disconnect the controller from the power supply by moving the main system switch to "off".

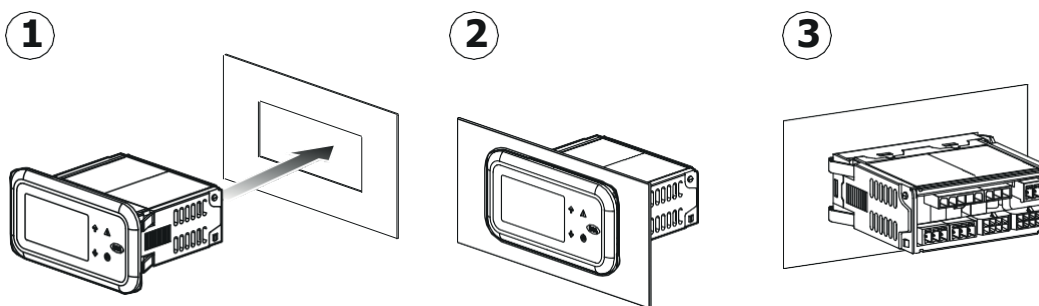

1. Place the controller in the opening, pressing lightly on the side anchoring tabs.
2. Then press on the front until fully inserted (the side tabs will bend, and the catches will attach the controller to the panel).

- ⚠ Caution: IP65 front protection is guaranteed only if the following conditions are met:
- maximum deviation of the rectangular opening from flat surface:  $\leq 0.5$  mm;
  - thickness of the electrical panel sheet metal: 0.8-2 mm;
  - maximum roughness of the surface where the gasket is applied:  $\leq 120$   $\mu$ m.

📌 Note: the thickness of the sheet metal (or material) used to make the electrical panel must be adequate to ensure safe and stable mounting of the product.

### 2.2.3 Removal

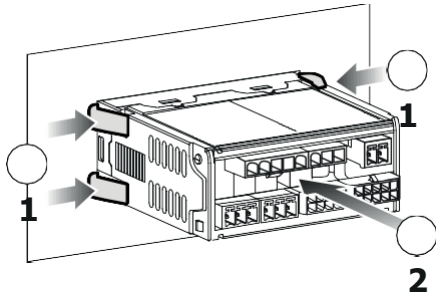

Open the electrical panel and from the back press on the anchoring tabs and then push the controller to remove it:

Gently press the side anchoring tabs on the controller; Exert slight pressure on the controller until it is removed.

**⚠ Caution:**  
the operation does not require the use of a screwdriver or other tools.

## 2.3 DIN rail version

### 2.3.1 Dimensions (mm)

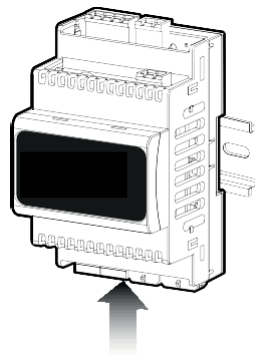
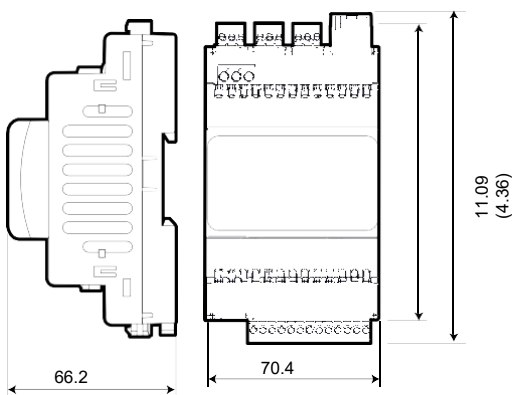

Apply slight pressure to the controller resting on the DIN rail until the rear tab clicks into place.

### 2.3.2 Removal

Use a screwdriver as a lever in the hole to lift and release the tab. The tab is held in the locked position by return springs.

## 2.4 Electrical installation

---

**⚠ Caution:**

before carrying out any maintenance, disconnect the controller from the power supply by moving the main system switch to "off".

**⚠ Caution:**

when laying the wiring, "physically" separate the power part from the regulation part. The proximity of these two sets of wires will, in most cases, cause problems of induced disturbance or, over time, malfunctions or damage to the components.

The ideal solution is to house these two circuits in two separate cabinets. Sometimes this is not possible, and therefore the power part and the regulation part must be installed in two separate areas inside the same panel.

For the regulation signals, it is recommended to use shielded cables with twisted wires. If the regulation cables have to cross over the power cables, the intersections must be as near as possible to 90 degrees, always avoiding running the regulation cables parallel to the power cables.

Pay attention to the following warnings:

- use cable ends suitable for the corresponding terminals. Loosen each screw and insert the cable ends, then tighten the screws. When the operation is completed, slightly tug the cables to check they are sufficiently tight;
- separate as much as possible the probe signal, digital input and serial line cables from the cables carrying inductive loads and power cables to avoid possible electromagnetic disturbance. Never run power cables (including the electrical cables) and probe signal cables in the same conduits. do not install the probe cables in the immediate vicinity of power devices (contactors, circuit breakers or similar);
- reduce the path of the probe cables as much as possible, and avoid spiral paths that enclose power devices;
- avoid touching or nearly touching the electronic components fitted on the boards to avoid electrostatic discharges (extremely damaging) from the operator to the components;
- do not secure the cables to the terminals by pressing the screwdriver with excessive force, to avoid damaging the controller: maximum tightening torque: 0.22-0.25 N•m.
- for applications subject to considerable vibrations (1.5 mm pk-pk 10/55 Hz), secure the cables connected to the controller around 3 cm from the connectors using clamps;
- all the extra low voltage connections (analogue and digital inputs, analogue outputs, serial bus connections, power supplies) must have reinforced or double insulation from the mains network.

## 2.4.1 Description of the terminals

Panel version

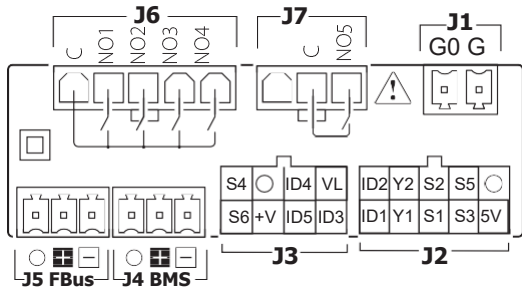

DIN rail version

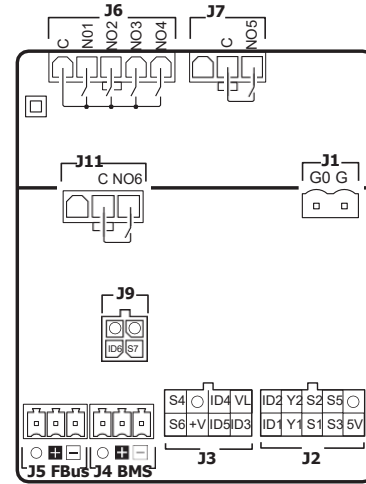

| Ref.                   | Description                              |                           |
|------------------------|--|---------------------------|
| J1                     | G 24 VAC/VDC power supply                |                           |
|                        | G0 Neutral                               |                           |
| J2                     | 5 V Ratiometric probe power supply       |                           |
|                        | S3 Analogue input 3 (not used)           |                           |
|                        | S1 Analogue input 1 (not used)           |                           |
|                        | Y1 Analogue output 1                     |                           |
|                        | ID1 Digital input 1                      |                           |
|                        | O Common GND                             |                           |
|                        | S5 Analogue input 5 (probe 3)            |                           |
|                        | S2 Analogue input 2 (not used)           |                           |
|                        | Y2 Analogue output 2                     |                           |
|                        | ID2 Digital input 2                      |                           |
|                        | ID3 Digital input 3 (not used)           |                           |
|                        | ID5 Digital input 5 (not used)           |                           |
|                        | +V Power supply to 4-20 mA active probes |                           |
| J3                     | S6 Analogue input 6 (probe 1)            |                           |
|                        | VL N/A                                   |                           |
|                        | ID4 Digital input 4 (not used)           |                           |
|                        | O Common GND                             |                           |
|                        | S4 Analogue input 4 (probe 2)            |                           |
|                        | J4                                       | - BMS port (RS485) Rx/Tx- |
|                        |  | + BMS port (RS485) Rx/Tx+ |
| O BMS port (RS485) GND |  |                           |

| Ref.                           | Description                     |
|--------------------------------|---------------------------------|
| J5                             | - Fieldbus port (RS485) Rx/Tx-  |
|                                | + Fieldbus port (RS485) Rx/Tx+  |
|                                | O Fieldbus port (RS485) GND     |
| J6                             | C Common for relays 1, 2, 3, 4  |
|                                | NO1 Digital output 1            |
|                                | NO2 Digital output 2            |
|                                | NO3 Digital output 3            |
| J7                             | NO4 Digital output 4            |
|                                | C Common for relay 5            |
|                                | NO5 Digital output 5 (alarm)    |
|                                | J9                              |
| ID6 Digital input 6 (not used) |                                 |
| O Common GND                   |                                 |
| J11                            | N/A                             |
|                                | C Common for relay 6            |
|                                | CN6 Digital output 6 (not used) |

## 2.5 Probe / digital input connection

Ratiometric pressure probes (0-5 V)

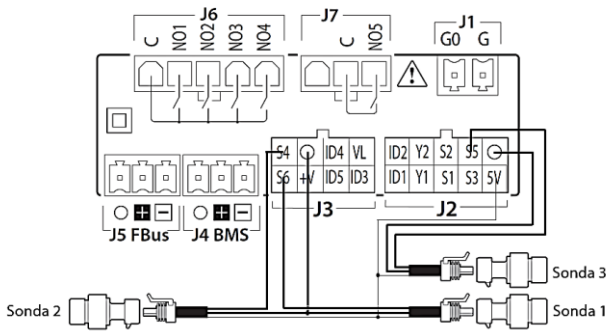

NTC / PT1000 temperature probes (PT1000 input S6 only)

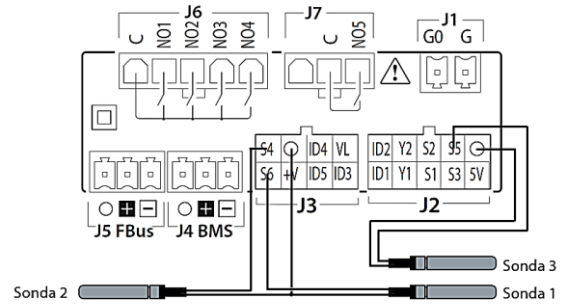

0-10 Vdc probes (input S6 only)

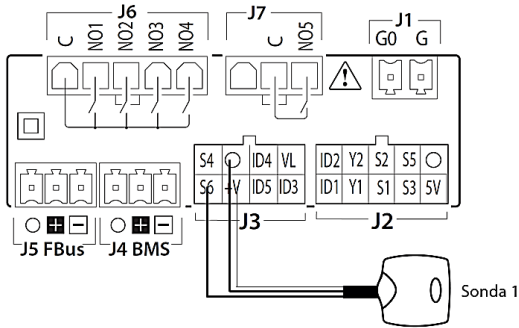

4-20 mA probes

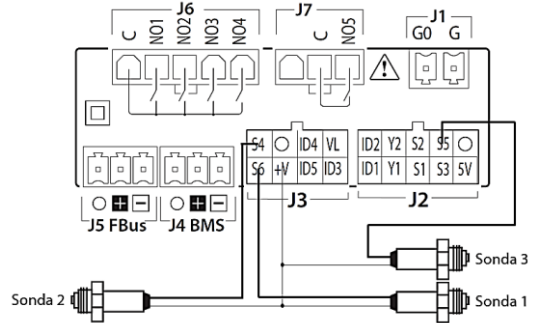

0-10 Vdc external signal (input S6 only)

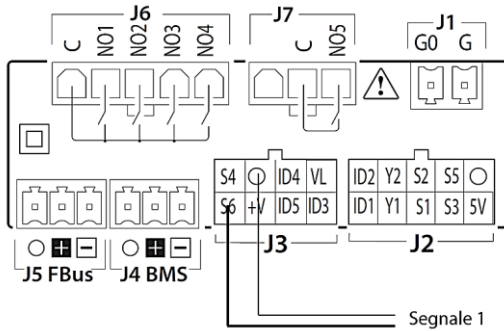

4-20 mA external signal

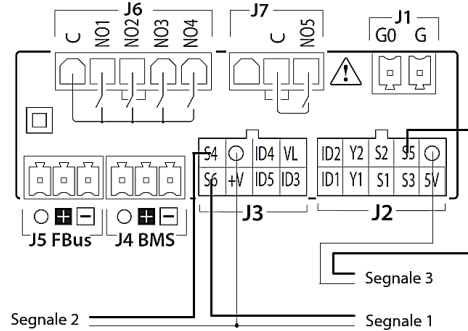

Digital inputs

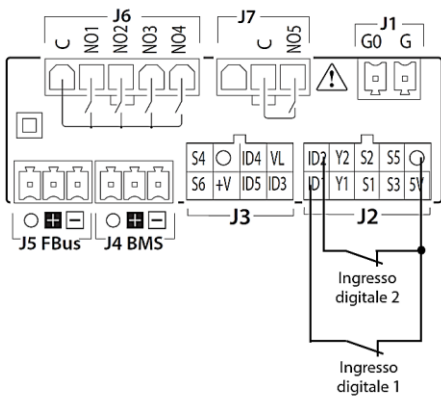

| Controller terminals | Terminal description |
|----------------------|----------------------|
| S4, S5, S6           | Analogue signal      |
| ID1, ID2             | Digital signal       |
| +V                   | Power supply         |
| 5 V                  | Power supply         |
| O                    | Reference / GND      |

## 2.6 Serial port connections

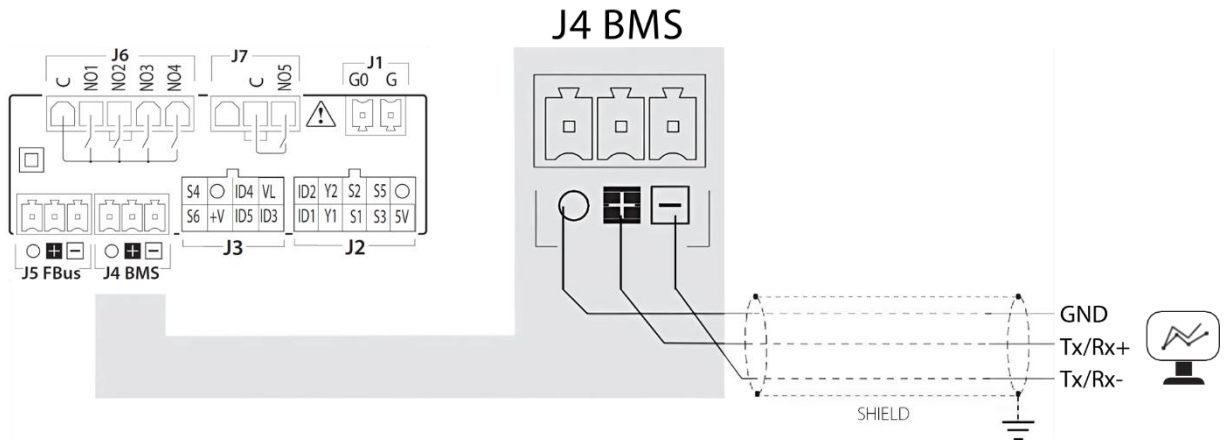

### Communication parameters

| Code | Description  | Value |
|------|--|-------|
| Hd00 | BMS address  | 1     |
| Hd01 | BMS baud rate<br>0=1200, 1=2400, 2=4800, 3=9600, 4=19200, 5=38400, 6=57600, 7=115200, 8=375000 | 4     |
| Hd02 | BMS network settings<br>0=8-NONE-1, 1=8-NONE-2, 2=8-EVEN-1, 3=8-EVEN-2, 4=8-ODD-1, 5=8-ODD-2   | 1     |

For further information see paragraph 7

## 2.7 Positioning inside the panel

The position of the controller in the electrical cabinet must be chosen so as to guarantee correct physical separation from the power components (solenoids, contactors, actuators, inverters, ...) and the connected cables. Proximity to such devices/cables may create random malfunctions that are not immediately evident. The structure of the panel must allow the correct flow of cooling air.

# 3. USER INTERFACE

## 3.1 Introduction

The Universal Controller uses the user terminal to display the alarms, the main variables and to set the unit set points (User level) and manual functions (Service level).

The terminal has a two-row 7-segment LED display: the top row shows 3 digits with sign and decimal point, while the bottom row shows 4 digits with sign. There is a buzzer, 14 operating icons and 4 buttons for scrolling and setting the parameters.

The terminal has Bluetooth connectivity to interact with mobile devices (installed with the Carel "Applica" app, available on Google Play for Android operating systems).

**Notice:**

- Access levels: User; Service; Manufacturer. See the parameter table in paragraph 6 for further information.
- The information and parameters accessible from the terminal and from the Applica app depend on the access level and the unit configuration parameters.

## 3.2 User terminal



Built-in regulation interface

### 3.2.1 Keypad

| Button | Description | Function   |
|--------|-------------|--|
|        | UP          | When scrolling: Previous menu/parameter<br>When programming: Increase value  |
|        | DOWN        | When scrolling: Next menu/parameter<br>When programming: Decrease value<br>On the main page: Display status and probes   |
|        | ALARM       | Pressed briefly: View active alarms and mute buzzer<br>Press and hold (3s): Reset alarms   |
|        | PRG         | When scrolling: Access menus/parameters<br>When programming: Confirm value<br>Pressed briefly: Access the main commands<br>Press and hold (3s): Access the main menu |

### 3.2.2 Icons

The icons indicate the operating status and operating modes, as shown in the following table.

| Button | Description | Function  |
|--------|-------------|---|
|        | HEAT        | Heating regulation active: Winter season or reverse logic   |
|        | COOL        | Cooling regulation active: Summer season or direct logic  |
|        | ALARM       | White icon: No active alarms<br>Flashing red icon: Alarms in progress not displayed<br>Red icon: Alarms in progress |

### 3.3 Display main page view

On startup, the user terminal will briefly display the current controller firmware revision.  
After that, the main page will be displayed.



The value displayed on the first row can be set by the user via parameter B020:

| Code | Description  | Default       |
|------|--|---------------|
| B020 | Display:<br>0=Probe 1<br>1=Probe 2<br>2=Digital input 1<br>3=Digital input 2<br>4=Set point 1<br>5=Set point 2<br>6=Probe 1/Probe 2 alternating<br>7=Output NO1 status<br>8=Output NO2 status<br>9=Output NO3 status<br>10=Output NO4 status<br>11=Output Y1 percentage<br>12=Output Y2 percentage<br>13=Probe 3<br>14=Control probe | Control probe |

On the bottom row, however, when the unit is switched off, "OFF" will be displayed, while when the unit is switched on, the status of the four regulation digital outputs will be shown, with a progressive number from left to right to indicate the digital outputs are activated/deactivated.

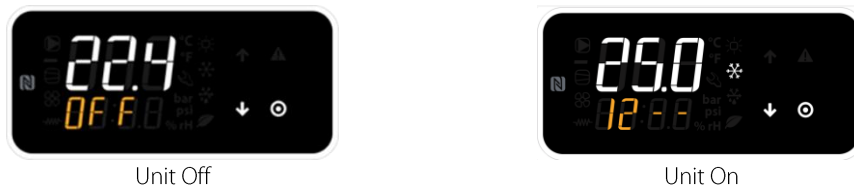

ⓘ Notice: "bLE" flashes on the display during "Bluetooth" communication.

### 3.3.1 Main unit values

From the main menu, the main controller operating values and unit status can be displayed:

| <b>Code</b> | <b>Description</b>       |
|-------------|--------------------------|
|             | Unit operating status    |
| On ----     | 0=Waiting                |
| Unit on     | 1=Unit ON                |
| OFF ALrM    | 2=OFF from alarm         |
|             | 3=Reserved               |
| OFF bMS     | 4=OFF from BMS           |
| OFF Schd    | 5=OFF from scheduler     |
| OFF dI      | 6=OFF from DI            |
| OFF diSP    | 7=OFF from display       |
|             | Season                   |
| SEaS        | 0=Summer                 |
|             | 1=Winter                 |
| rEGt        | Control probe reading    |
| rSt1        | Control set point 1      |
| rSt2        | Control set point 2      |
| Prb1        | Probe 1 reading          |
| Prb2        | Probe 2 reading          |
| Prb3        | Probe 3 reading          |
| din1        | Digital input 1 reading  |
| din2        | Digital input 2 reading  |
|             | Relay status             |
|             | Relay 1                  |
| do          | Relay 2                  |
|             | Relay 3                  |
|             | Relay 4                  |
| dou5        | Relay 5 status           |
| Y1          | Analogue output 1 %      |
| Y2          | Analogue output 2 %      |
| 000 000h    | Unit operating hours     |
| 000 000h1   | Output 1 operating hours |
| 000 000h2   | Output 2 operating hours |
| 000 000h3   | Output 3 operating hours |
| 000 000h4   | Output 4 operating hours |
| rEL         | Firmware version         |
| dAY         | Day                      |
| Mont        | Month                    |
| YEAr        | Year                     |
|             | Day of the week          |
|             | 0=Sunday                 |
|             | 1=Monday                 |
| UdAY        | 2=Tuesday                |
|             | 3=Wednesday              |
|             | 4=Thursday               |
|             | 5=Friday                 |
|             | 6=Saturday               |
| Hour        | Hours                    |
| Min         | Minutes                  |

The following procedure shows how to access the main unit values category:



1. Display the main regulation page. A value or status will be shown, as set for parameter B020.



2. Press DOWN to access the main unit values display. The current unit status will be shown first, in the example the status is "Off from Display".



3. Press UP and DOWN to scroll through the read-only parameters in the menu. Note that, compared to the first view, the other read-only parameters are displayed with the bottom row showing the parameter code, while the top row shows the current value.



4. Select ESC and press PRG to return to the main page.

### 3.3.2 Direct access parameters

From the user terminal it is possible to access the basic configuration parameters and the main commands without entering a password, or, on entering a password, the unit configuration and optimisation parameters.

Below is the list of parameters accessible without entering a password:

| Code | Description                 | Default |
|------|-----------------------------|---------|
| UnSt | Set unit on/off from keypad | Off     |
| St1  | Set point 1                 | 20.0    |
| St2  | Set point 2                 | 40.0    |
| St1E | Set point 1 in economy mode | 15.0    |
| St2E | Set point 2 in economy mode | 35.0    |
| SEa1 | Circuit 1 season            | Summer  |
| SEa2 | Circuit 2 season            | Summer  |

The procedure described below describes how to access the direct access parameter category and enter programming mode:

|   |   |   |
|---|---|---|
|  <p>1. Display the main regulation page. A value or status will be shown, as set for parameter B020.</p> |  <p>2. Press PRG for less than 3 s and then release it to access the direct access parameter display. Note that in the parameter list view, the bottom row shows the parameter code, while the top row shows the current value. In the example, parameter UnSt is set to OFF.</p> |  <p>3. Press UP and DOWN to scroll through the menu parameters, press PRG to enter parameter setting mode, as indicated by the value flashing.</p>   |
|  <p>3. Use UP and DOWN to change the value. Press PRG to confirm the displayed value.</p>              |  <p>4. On exiting parameter setting mode, use UP and DOWN again to scroll through the menu parameters, as described in point 3.</p>   |  <p>5. Some parameters are only displayed if the related regulation function or configuration has been enabled. In the example, parameter St1E (Economy set point 1) is only shown if the scheduler is enabled via parameter Hb00.</p> |
|  <p>6. Select ESC and press PRG to return to the main page.</p>                                       |   |   |

ⓘ Notice: The direct access parameters are automatically saved when exiting parameter setting mode.

### 3.3.3 Access the programming menu

To prevent accidental changes to the main controller configuration parameters, the programming menu can only be accessed on entering a password.

The login procedure is as follows:

|  |   |   |
|--|---|---|
|  <p>1. Go to the main regulation page and press and hold PRG for more than 3 seconds.<br/>When releasing the button, the password entry prompt (PSd) will be shown.</p> |  <p>2. Press PRG: the first digit of the password will start flashing to indicate that it can be changed using the UP and DOWN buttons.</p> |  <p>3. Set the value and press PRG to confirm. Now the second digit will start flashing. Repeat for each digit to enter the required password.</p> |
|  <p>4. The last time PRG is pressed, the four digits will be verified and if the password entered is correct, the scrollable programming menu will be shown.</p>        |  <p>5. Press UP and DOWN to scroll through the programming menus, press PRG button to access the parameters in the selected menu.</p>       |  <p>6. Press UP and DOWN to scroll through the menu parameters, press PRG to enter parameter setting mode, as indicated by the value flashing.</p> |
|  <p>7. In programming mode, to change the value press UP and DOWN, while to confirm press PRG; the value will stop flashing.</p>                                      |  <p>8. From the parameter, press ESC and PRG to return to the menu. In the menu, press ESC to return to the main regulation page.</p>     |   |

- 🔔 Notice:
- Default User password: 0000.
  - Default Service password: 1234.
  - Default Manufacturer password: 5678.
  - The passwords can only be changed from Applica Mobile and Applica Desktop.
  - The Service password also provides access to the user parameters;
  - The Manufacturer password provides access to all the parameters.

### 3.3.4 Programming menu

Once having accessed the programming menu, select one of the following menus to access the parameter list for a specific category (see paragraph 6 for further details on the parameters):

|  |   |  |
|--|---|--|
|  |   |  |
| <p><b>Category IO / Conf<br/>(Input/Output)</b></p>  | <p><b>Category Ctr / Conf<br/>(Control configuration)</b></p>   | <p><b>Category ALM / Conf<br/>(Alarms)</b></p>   |
| <p>Identified by code loxx, these parameters relate to the configuration of the regulation inputs and outputs.</p> | <p>Identified by code Bxxx, these parameters relate to the controller configuration. They also include PID parameters and special parameters.</p> | <p>Identified by code Cxxx, these parameters relate to the alarm configuration.</p>                                  |
|  |   |  |
| <p><b>Category CLc / Menu<br/>(Clock)</b></p>  | <p><b>Category Sch / Menu<br/>(Scheduler)</b></p>   | <p><b>Category Hst / Menu<br/>(Alarm log)</b></p>  |
| <p>These include the date and time setting parameters.</p>   | <p>Identified by code Hbxx, these parameters are used for setting and managing the time bands, special days and vacation periods.</p>             | <p>Access to the alarm log. Each event is described alternately by an alarm code and the time (in hh:mm format).</p> |
|  |   |  |
| <p><b>Category StG / Menu<br/>(Settings)</b></p>   | <p><b>Log Out</b></p>   | <p><b>ESC</b></p>  |
| <p>Identified by code Hdxx, these parameters relate to the network and hardware settings.</p>                      | <p>Log Out command to exit the main menu and log out the user.</p>  | <p>Press ESC and then PRG to exit the programming menu.</p>  |

**Notes**

- If no button is pressed, after approximately 1 minute (time set by parameter Hd99), the terminal automatically returns to display the main page.
- The parameters are automatically saved when exiting parameter programming mode.
- When initialising via parameter rStr (either from the display or from Applica), wait until the application has completed the automatic restart, as indicated by the current firmware version shown on the display.
- Initialisation via parameter rStr is recommended before changing operating mode (parameter B000).

# 4. COMMISSIONING

The Universal Controller user terminal contains a subset of the available regulation and configuration parameters (see paragraph 6). Consequently, the user terminal cannot be used to configure the Universal Controller.

This is done using Applica, an application that is available in two formats:

1. Applica mobile (see paragraph 4.1 Applica app)
2. Applica desktop (see paragraph 4.3 Applica Desktop)

Applica can connect to the Universal Controller and access the complete list of configuration parameters.

## 4.1 Applica app

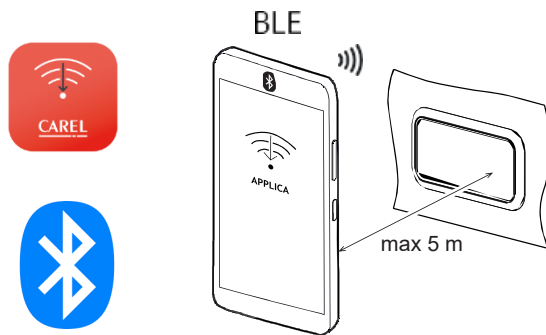

The “Applica” app can be used to configure the controller from a mobile device (smartphone, tablet), via Bluetooth (BLE). Users can both configure the commissioning parameters and set groups of parameters according to specific needs (configurations).

### 4.1.1 Connection to the controller

Below is the connection procedure to be followed once the Carel “Applica” app has been installed and is running:

1. Select Bluetooth
2. The controllers available for connection will be listed. Select the desired controller
3. Accept the pairing request between the smartphone/tablet and the controller

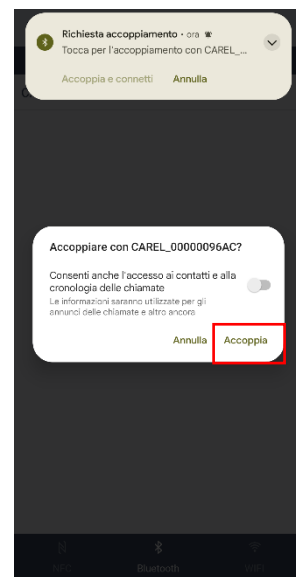
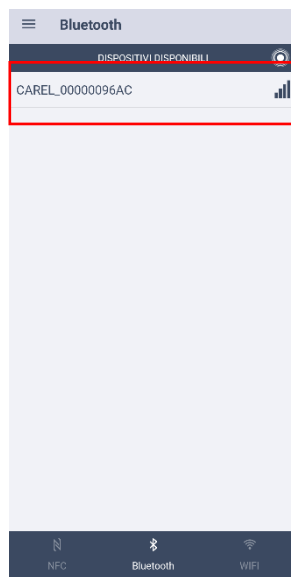
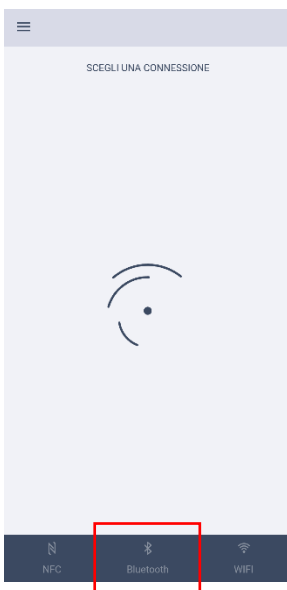

4. A pop-up message will be shown to choose the access profile

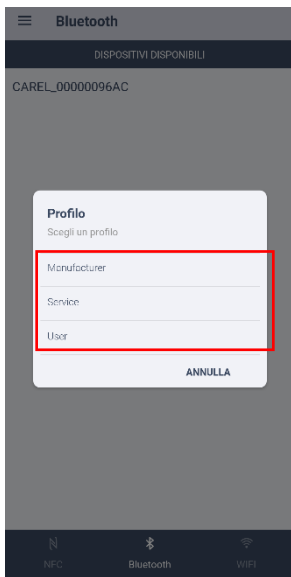

5. Enter the password for the chosen profile (see paragraph 3.3.3) and select OK

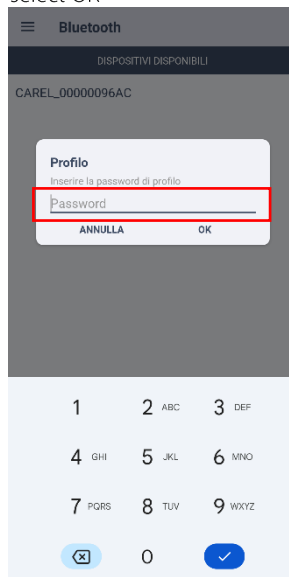

6. The app home page will be shown



## 4.2 Configuration procedure

### 4.2.1 Main sections

The mobile app main screen shows the following information:

1. Values measured by the probes
  - Probe 1
  - Probe 2 (if configured)
  - Probe 3 (if configured)
2. Operating status
  - Unit status
  - Season (if configured)
  - Time bands (if configured)
3. Values measured by the digital inputs (if configured)
4. Commands sent to analogue and digital outputs

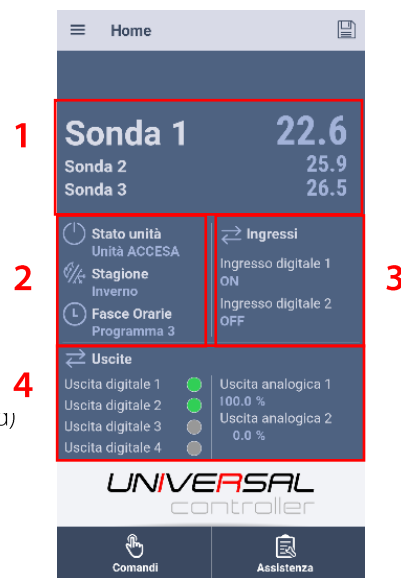

The "Commands" section contains the main unit commands and settings, such as On/Off, circuit heat/cool mode setting and the various set points:

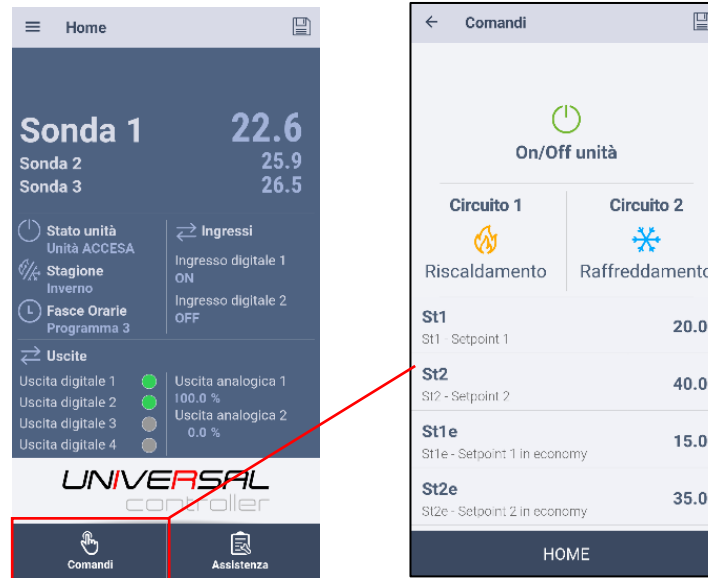

Tapping the "Service" button accesses the configuration parameter settings menu, divided based on the category (regulation, scheduler, IO configuration and alarm configuration), as well as the complete list of read-only values (Information).

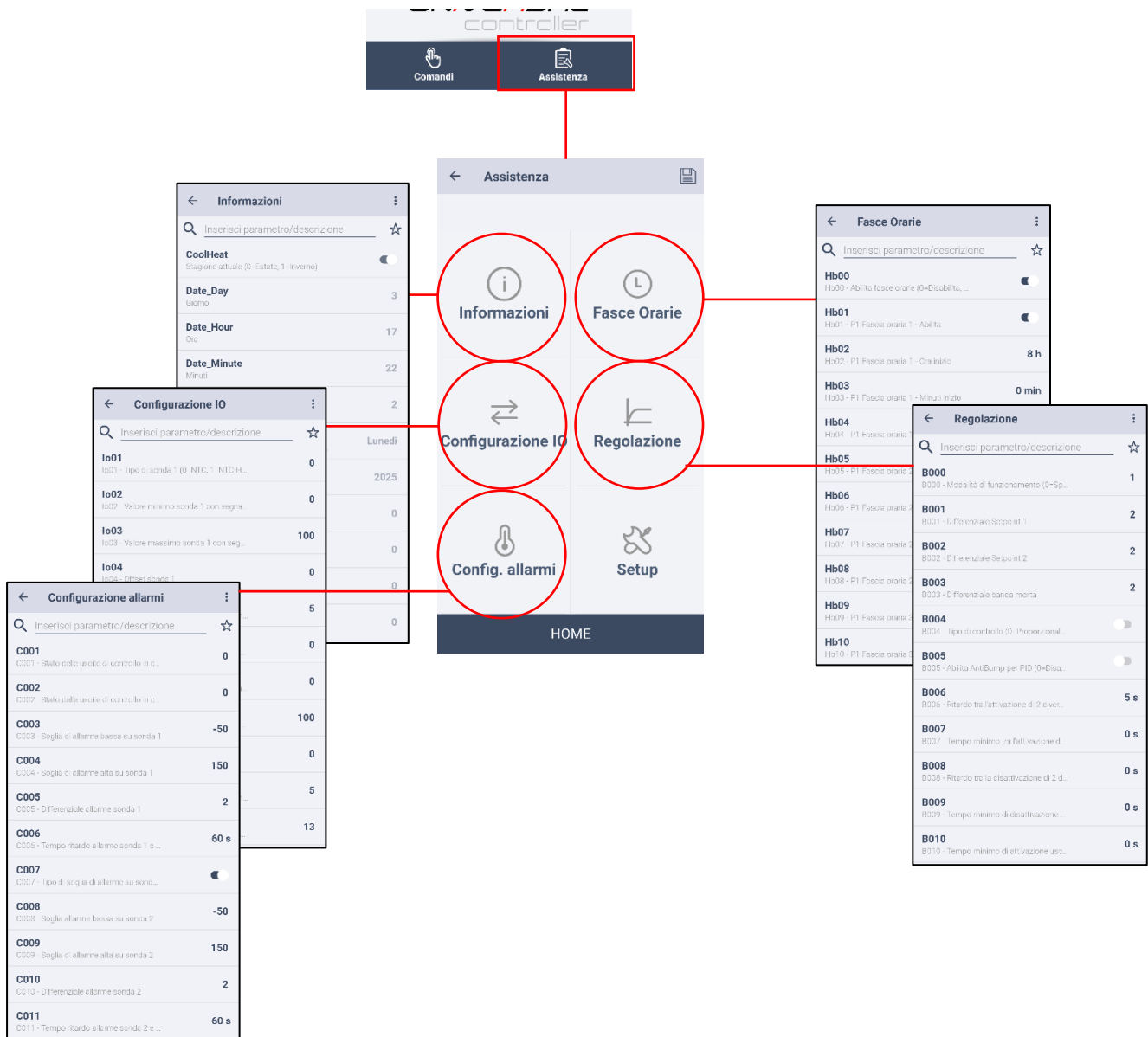

The "Setup" section contains the settings needed to configure the controller, such as the parameter list, unit configurations, communication and network parameters, change ID and upgrade FW:

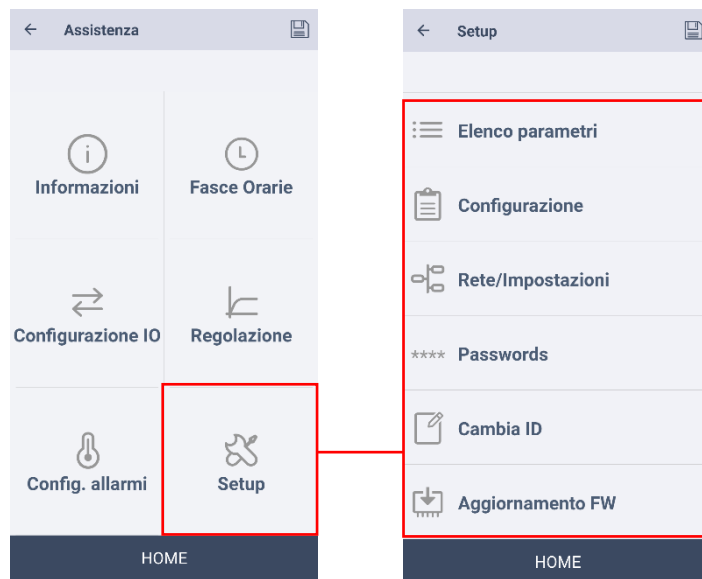

The side menu, accessible from the home page, contains shortcuts to access the main settings and information, such as the parameter list, alarm management, and configurations:

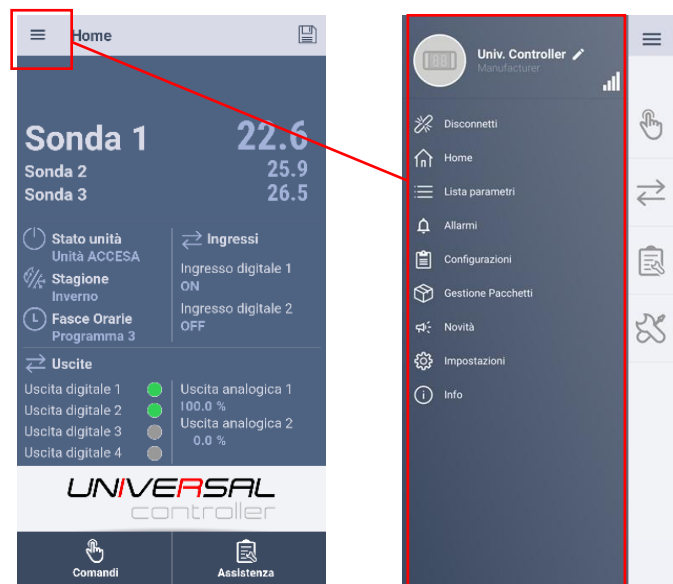

## 4.2.2 Parameter list

The parameter list shows all the parameters that can be read and set by the user.

For simpler navigation, the Applica app features filters to group the parameters by type and category.

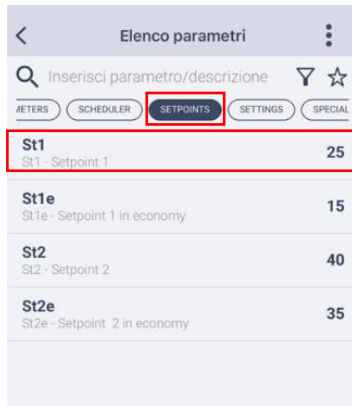

To apply a filter, simply tap the funnel icon at the top right and select one or more categories.

Alternatively, scroll through the horizontal list in the basic view and tap the individual category.

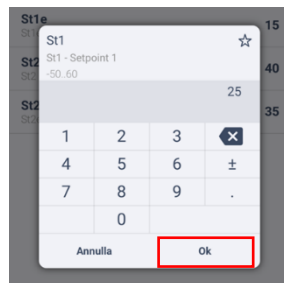

To set the value of a parameter, click the parameter, enter the desired value and tap "Ok" to confirm.

The value will be updated, and an asterisk (\*) will be shown alongside while the value is being written to the controller.



### 4.2.3 Create a unit configuration

Applica includes a "Save Configuration" feature, used to create custom unit configurations.

The saved configurations include all the parameters that can be customised by the user; these can also be used on multiple controllers, for rapid custom configuration of multiple units.

Proceed as follows:

1. At the top right of each menu there is an icon representing the "Save configuration" function.



2. Tap the icon and assign a name to the configuration, then tap "Ok" to save



To apply a previously saved configuration, proceed as follows:

1. Go to the Service menu and tap Setup



2. Tap the Configuration item

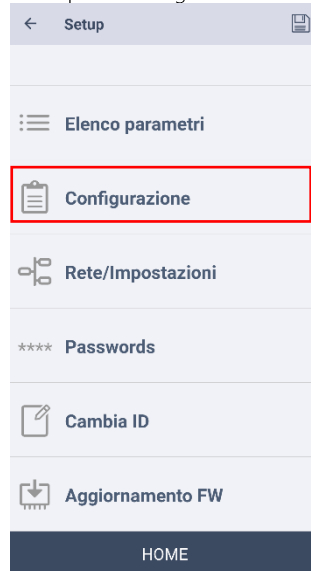

3. Choose the desired configuration

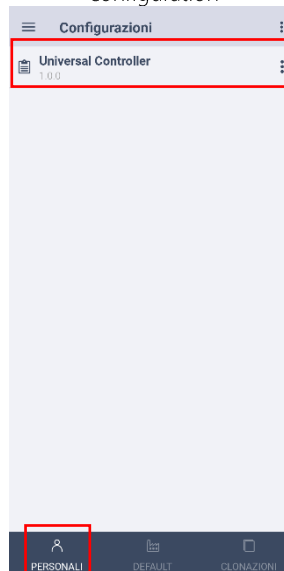

4. Apply the configuration

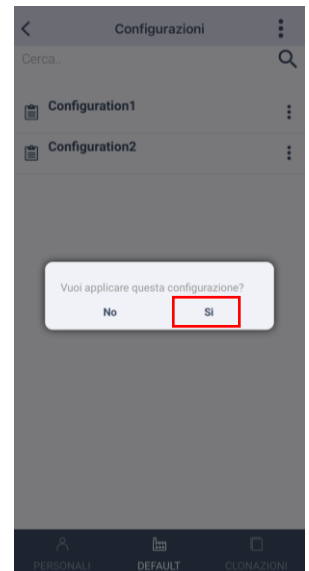

Alternatively, the configurations can also be applied using the following procedure:

1. Open the side menu and tap Settings

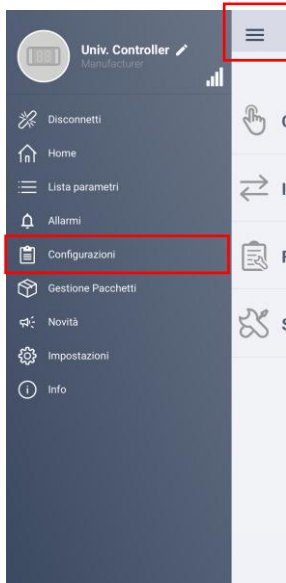

2. Choose a configuration

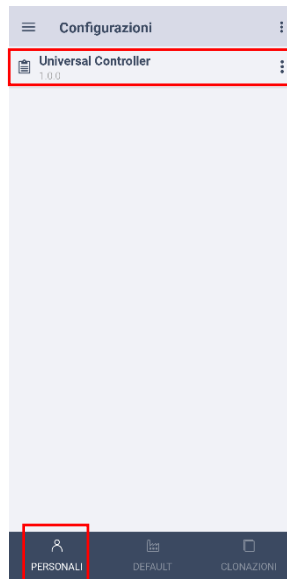

3. Apply the configuration

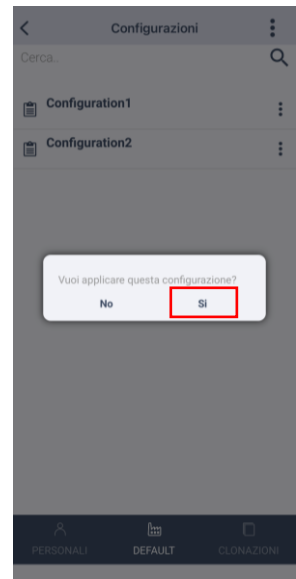

## 4.2.4 FW update

In the Applica app, the controller firmware can be updated from the "Setup" menu.

Proceed as follows:

1. Go to the Setup menu and tap the "Update FW" item. Tap "OK"



2. The smartphone file manager app will open. Select the desired .pack file



3. Applica will show information on the selected .pack. After confirming by tapping "Ok", the firmware will be installed

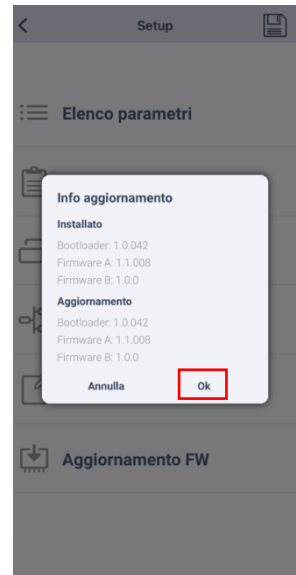

At the end of the procedure, the controller will reboot to apply the new firmware. Connect to the controller again via Bluetooth.

## 4.3 Applica Desktop

Applica Desktop is a program intended for manufacturers and installers of units equipped with the Universal Controller. It can be downloaded from [ksa.carel.com](http://ksa.carel.com).

Applica Desktop offers the possibility to:

- access the controller using the assigned profile;
- create configurations;
- apply configurations;
- clone a unit configuration, i.e. copy all of the unit's parameter values;
- complete the commissioning procedure;
- troubleshoot any problems on the unit.

**Notice:**

Applica Desktop can be used as an alternative to the Applica app, and requires an internet connection; For the physical connection to the Universal Controller's BMS port, use the USB/RS485 converter P/N CVSTDUMORO.

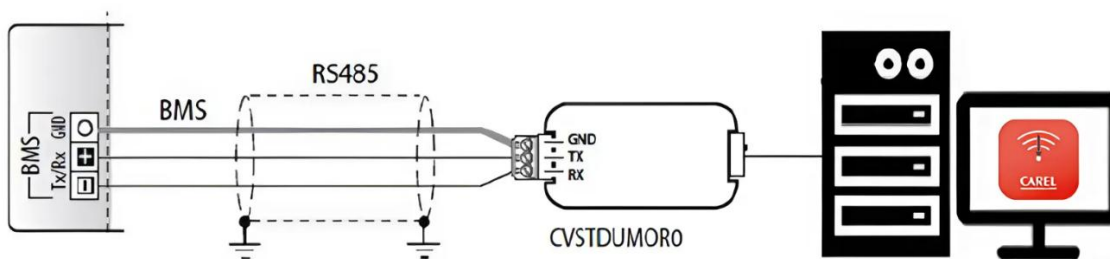

### 4.3.1 Connection to the controller

1. Connect to the Universal Controller's BMS port using the USB/RS485 converter P/N CVSTDUMORO;
2. Open Applica Desktop; a window will open with the top bar of the work area as shown in the figure:



3. Select "Add Target" and assign it a meaningful name (e.g. "Universal Controller");
4. In the "COM Port" field, enter the COM port used for the USB connection to the USB/RS485 converter.
5. Configure the connection parameters as shown in the figure (the data are saved automatically);
6. Click "Connect" to connect to the Universal Controller (this must already be powered on);

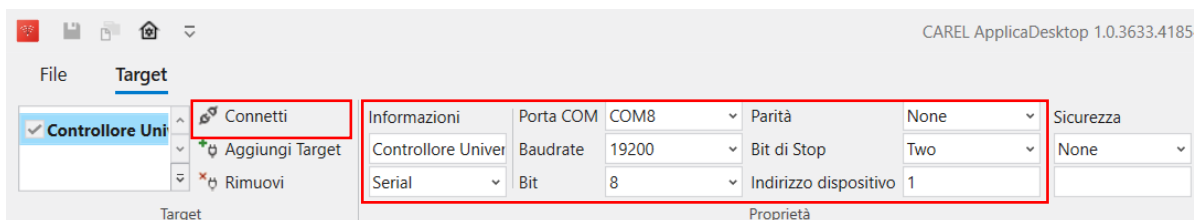

7. To complete the connection to the controller, choose the desired access level and enter the corresponding password (see paragraph 3.3.3).

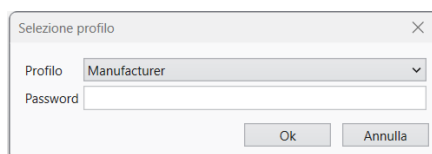

## 4.4 Setup procedure with Applica Desktop

### 4.4.1 Create a unit configuration

1. Select the "Configurations" section, click the "New" icon and then "New Configuration".

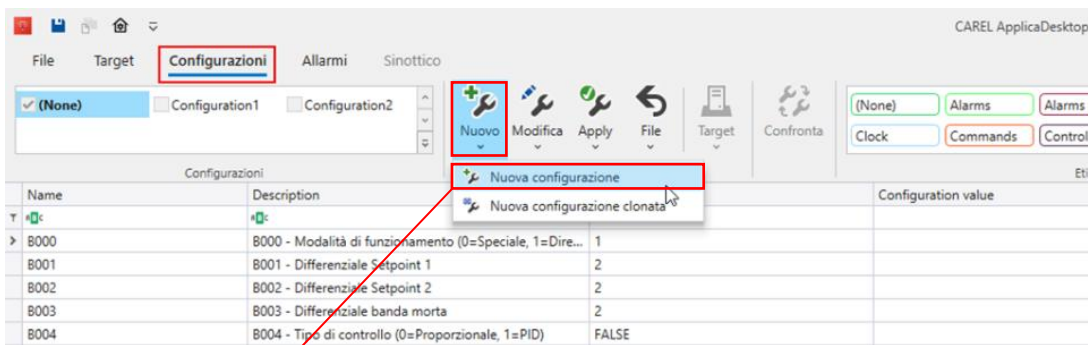

A

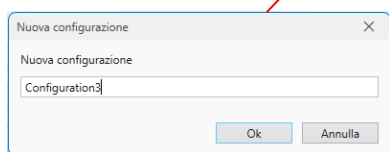

new window will open with a prompt to enter a name for the new configuration being created.

2. Select the new configuration, then "Edit -> Apply real values". This operation copies the values of the parameters currently saved on the connected Universal Controller to the newly created configuration.

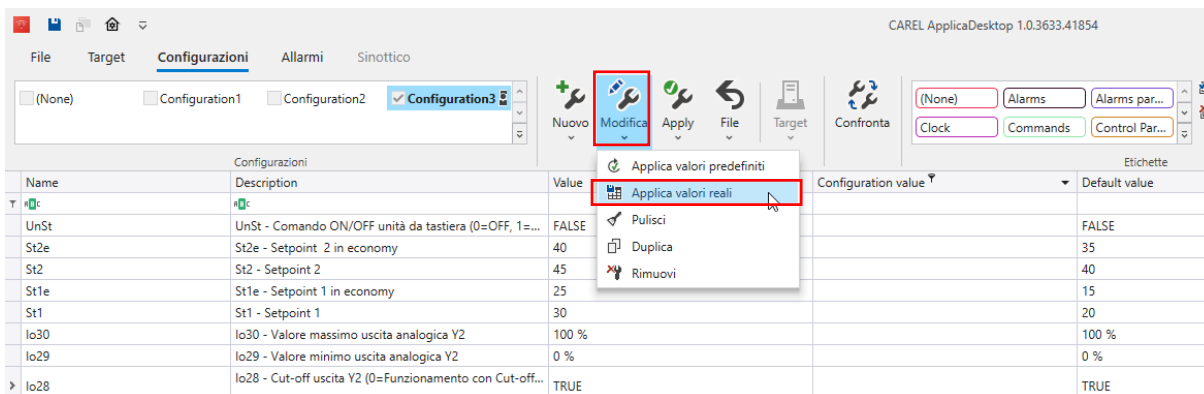

The configuration values are listed in the "Configuration value" column, while the "Default value" column shows the default values of the parameters defined by the application.

Only the values in the first column can be set, so as to customise the currently selected configuration.

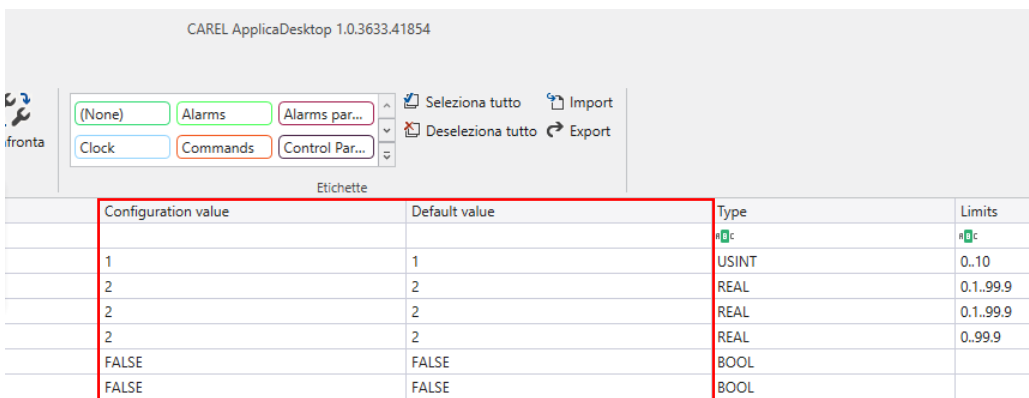

- From the top section containing the Tags, select IO configuration to set the input and output configuration parameters.

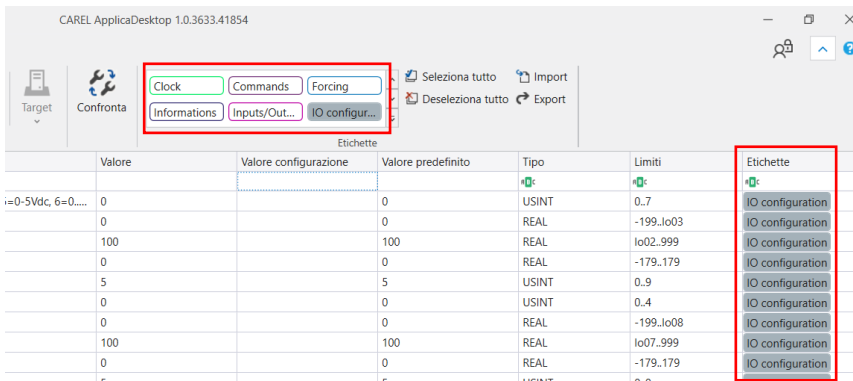

- Set the parameters listed in the "Configuration value" column to configure the unit.
  - Repeat steps 3 and 4 for the "Control" and "Main parameters" tags.
  - The unit has now been configured. If desired, the regulation parameters can be set using the other available tags as a search filter.
  - To apply the new configuration to the controller, select one of the created configurations, then click the Applica icon and then Apply configuration.
- The values of the configuration parameters (shown in the "Configuration value" column) have now been applied.

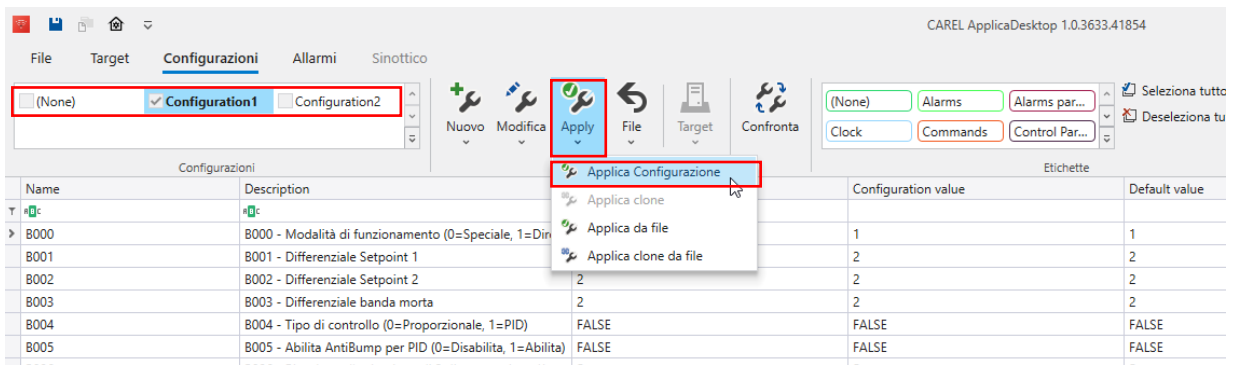

Finally, to save the newly-created configuration for future use, from the "Configurations" section select "File -> Export" and assign a name to the configuration being saved.

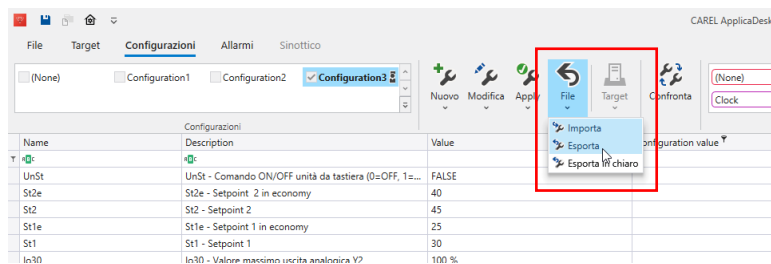

#### 4.4.2 Date and time setting

Applica Desktop has a function for aligning the controller's date and time with the values set on the connected PC.

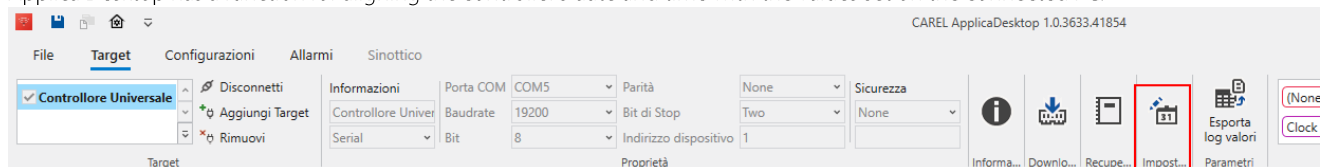

Once having connected to the controller, click "Set date/time" and then confirm in the pop-up that will be displayed.

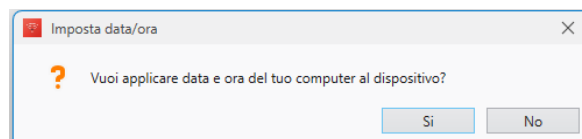

### 4.4.3 Parameter list

The list of parameters and variables is shown in the “Target” section. To simplify parameter searching and management, Applica Desktop features filters that group parameters by type and category.

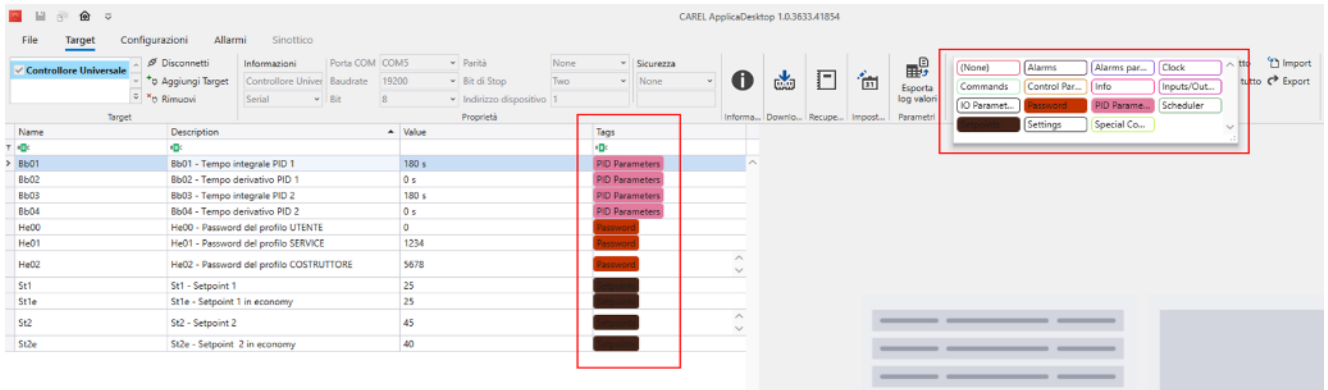

To apply a filter, simply select one or more desired categories from the list at the top right or alternatively move the mouse pointer to the beginning of the column (in this case Tags, however the same applies to all the other columns) and click the funnel icon to select the values to be filtered or apply a rule.

To set the parameter value, click it in the “Value” column and enter the new value.

### 4.4.4 FW update

In Applica Desktop, the controller firmware can be updated from the “Target” section.

To start the update click “Download” and select the desired .pack file in file explorer:

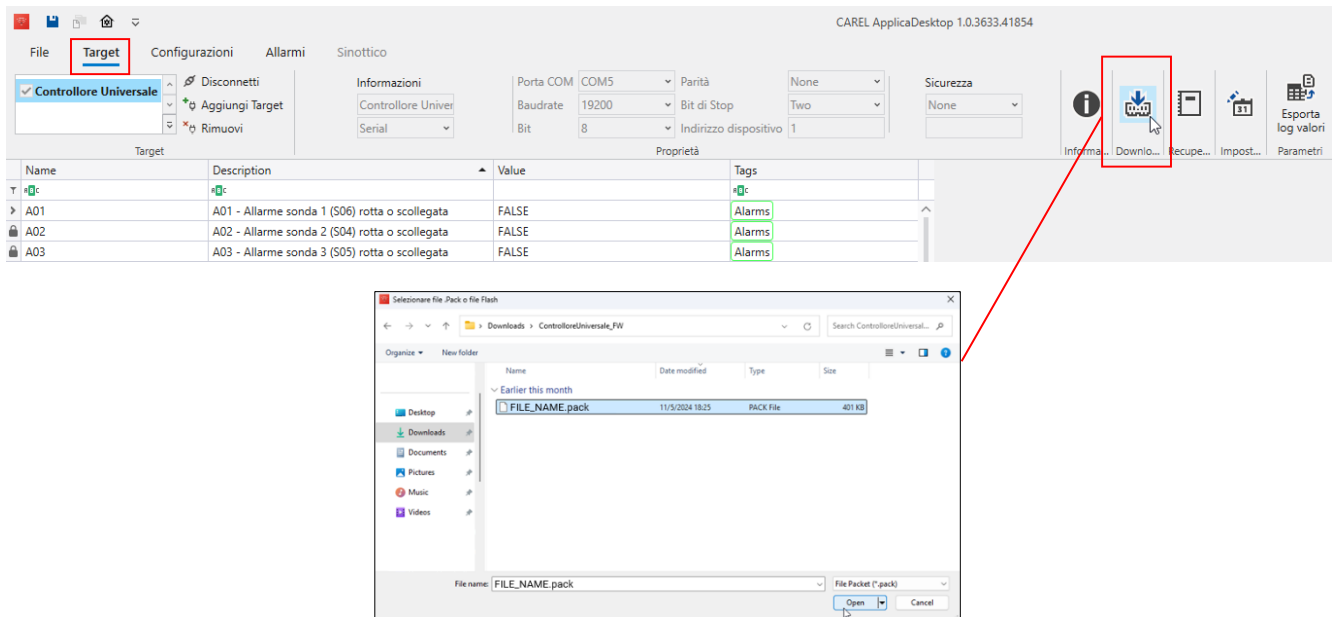

At the end of the procedure, the controller will reboot to apply the new firmware.

# 5. FUNCTIONS

## 5.1 Standard operating modes

The controller can operate in eight standard regulation modes (for the case where B000=0, see paragraph 5.4), selectable via parameter B000:

| Code | Description  | Default |
|------|--|---------|
| B000 | Operating mode:<br><i>0=Special operation (custom)</i><br><i>1=Direct</i><br><i>2=Reverse</i><br><i>3=Neutral zone</i><br><i>4=Reserved</i><br><i>5=Reserved</i><br><i>6=Direct/reverse changeover from DI1</i><br><i>7=Direct: set point and differential from DI1</i><br><i>8=Reverse: set point and differential from DI1</i><br><i>9=Direct/reverse with two separate set points</i><br><i>10=3 position valve</i> | Direct  |

The basic modes are "Direct" and "Reverse":

- In "Direct" mode, the output is activated if the value measured exceeds the set point plus a differential.
- In "Reverse" mode, the output is activated if the temperature is lower than the set point minus a differential.

The other modes are a combination of the two, with the possibility of using two set points (St1 and St2) and two corresponding differentials (B001 and B002), according either "Direct" and "Reverse" operation or the status of digital input 1. The other options are "Neutral zone" and "3-position valve" operation.

Selecting the correct operating mode is the first action to be completed if the factory configuration, i.e. "Direct" operation, is not suitable for the specific application.

Each mode can use one of the following types of regulation:

- On-Off with hysteresis
- Proportional
- PID (proportional + integral + derivative)

The main parameters are as follows:

| Code | Description               | Default |
|------|---------------------------|---------|
| St1  | Set point 1               | 20.0    |
| B001 | Set point 1 differential  | 2.0     |
| St2  | Set point 2               | 40.0    |
| B002 | Set point 2 differential  | 2.0     |
| B003 | Neutral zone differential | 2.0     |

The following parameters are available specifically for PID regulation:

| Code | Description  | Default |
|------|--|---------|
| B004 | Control type:<br><i>0=Proportional</i><br><i>1=PID</i> | 0       |
| Bb01 | Control Ti 1   | 180 sec |
| Bb02 | Control Td 1   | 0 sec   |
| Bb03 | Control Ti 2   | 180 sec |
| Bb04 | Control Td 2   | 0 sec   |

The PID regulation features also a special anti-bump filter that serves to smooth the output following changes to the regulation set point and/or differential.

The anti-bump filter can be enabled or disabled via parameter B005.

⚠ Notice: initialisation via parameter rStr is recommended before changing operating mode via parameter B000.

### 5.1.1 Mode 1: Direct (B000=1)

In "Direct" operation, the controller works to contain the measured value when it exceeds the set point (St1). The four digital outputs are activated in sequence, while the two analogue outputs follow the request from the PID or proportional logic.

Digital output activation is evenly distributed across the set differential (B001).

When the measured value is greater than or equal to St1+B001 (in proportional-only operation), all the digital outputs are activated, and the analogue outputs will supply the maximum possible voltage (based on the configured limits). Similarly, if the measured value starts to fall, the outputs are deactivated in sequence and the analogue output voltage will decrease.

On reaching St1, all the outputs are deactivated and the analogue outputs will supply the minimum possible voltage (based on the configured limits).

The controller can be switched to Reverse mode via summer/winter changeover from digital input and/or parameter SEa1.

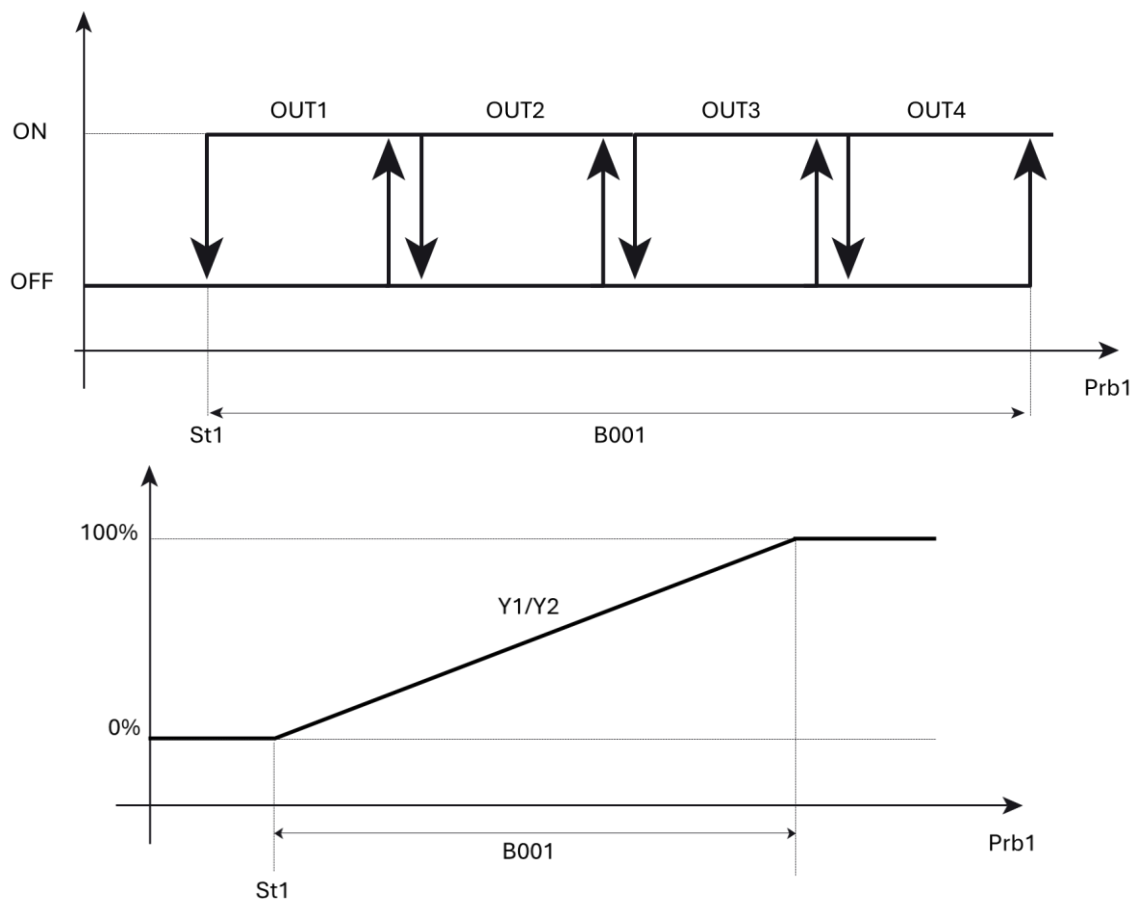

| Key         | Description              |
|-------------|--------------------------|
| St1         | Set point 1              |
| B001        | Set point 1 differential |
| OUT 1/2/3/4 | Digital outputs 1/2/3/4  |
| Y1/Y2       | Analogue outputs 1/2     |
| Prb1        | Probe 1                  |

## 5.1.2 Mode 2: Reverse (B000=2)

“Reverse” operation is similar to the “Direct” operation, however the outputs are activated when the regulated value falls below the set point (St1). The four digital outputs are activated in sequence, while the two analogue outputs follow the request from the PID or proportional logic.

Digital output activation is evenly distributed across the set differential (B001).

When the measured value is less than or equal to St1-B001 (in proportional-only operation), all the digital outputs are activated, and the analogue outputs will supply the maximum possible voltage (based on the configured limits). Similarly, if the measured value starts to rise, the outputs are deactivated in sequence and the analogue output voltage will decrease.

On reaching St1, all the outputs are deactivated and the analogue outputs will supply the minimum possible voltage (based on the configured limits).

The controller can be switched to Direct mode via summer/winter changeover from digital input and/or parameter SEa1.

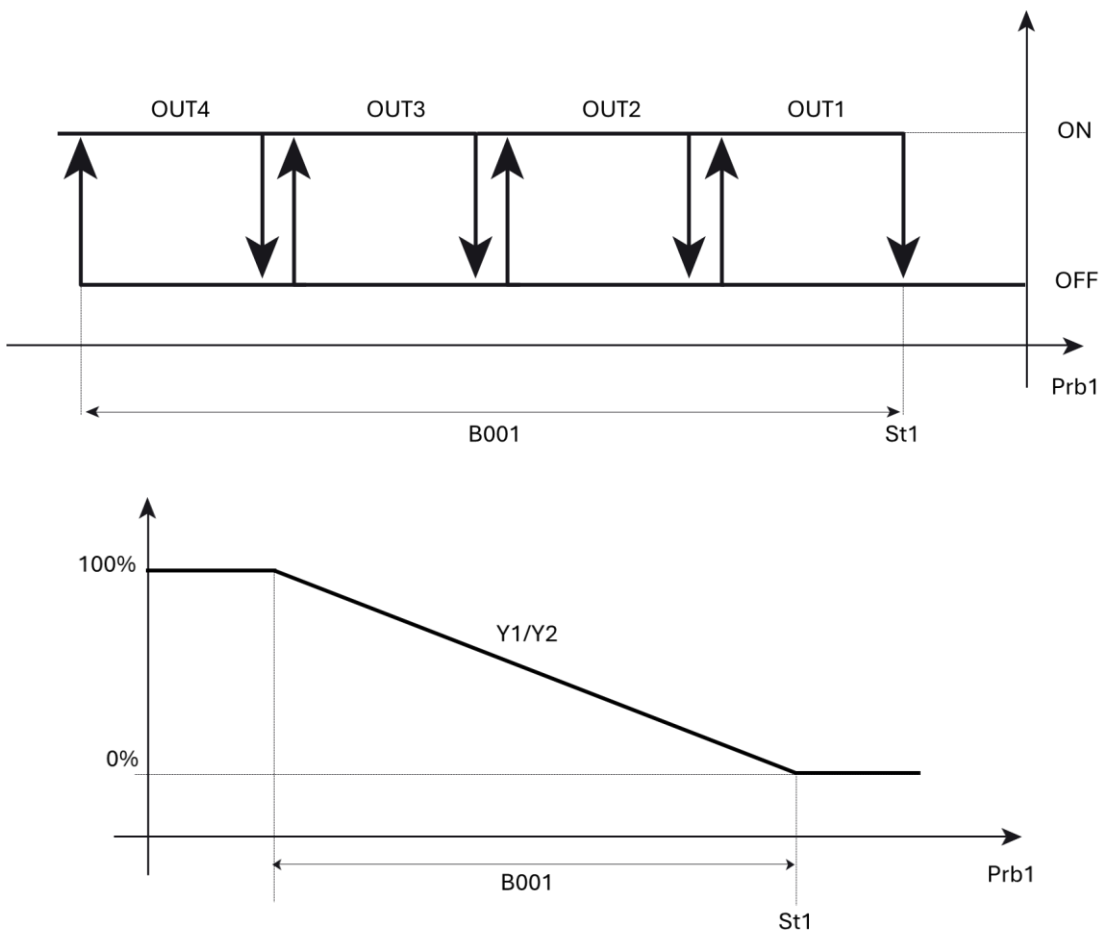

| Key         | Description              |
|-------------|--------------------------|
| St1         | Set point 1              |
| B001        | Set point 1 differential |
| OUT 1/2/3/4 | Digital outputs 1/2/3/4  |
| Y1/Y2       | Analogue outputs 1/2     |
| Prb1        | Probe 1                  |

### 5.1.3 Mode 3: Neutral zone (B000=3)

The purpose of "Neutral zone" operation is to bring the measured value within a certain range around the set point (St1), called the neutral zone. This range can be set using parameter B003.

Inside the neutral zone, the controller does not activate any of the outputs, while outside of the zone it works in "Direct" mode when the value is increasing and in "Reverse" mode when it is decreasing.

Digital outputs OUT 1 and 2 and analogue output Y1 will work in "Reverse" mode, while digital outputs OUT 3 and 4 and analogue output Y2 will work in "Direct" mode.

These are activated and deactivated individually or will supply a higher or lower voltage as previously described for modes 1 and 2, depending on the measured value and the settings of St1, B001 for "Reverse" regulation and B002 for "Direct" regulation.

Season changeover is not available in this mode.

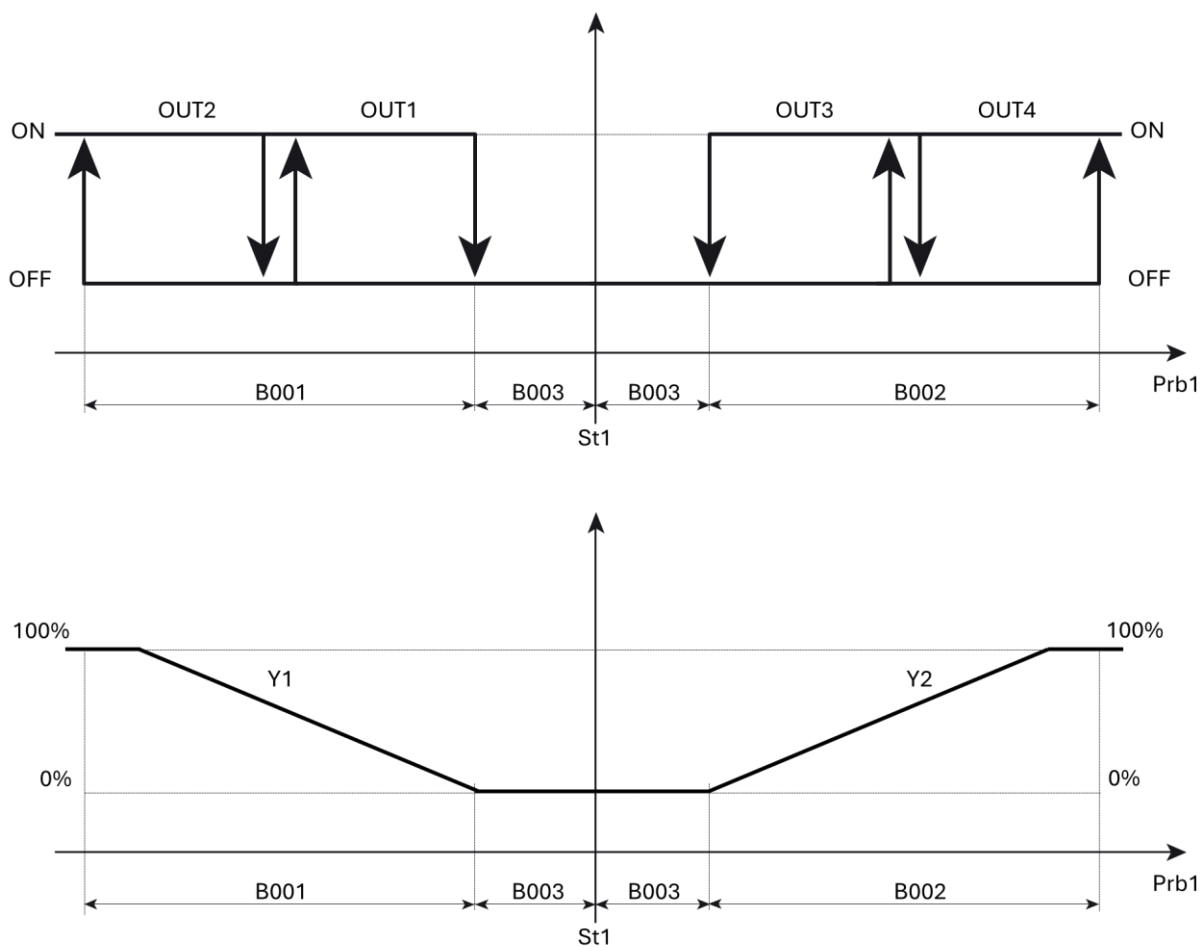

| Key         | Description                       |
|-------------|-----------------------------------|
| St1         | Set point 1                       |
| B001 / B002 | "Reverse" / "direct" differential |
| B003        | Neutral zone differential         |
| OUT 1/2/3/4 | Digital outputs 1/2/3/4           |
| Y1/Y2       | Analogue outputs 1/2              |
| Prb1        | Probe 1                           |

### 5.1.4 Mode 6: Direct/reverse changeover from DI1 (B000=6)

The controller works in "Direct" mode with reference to St1 when digital input 1 is open, and in "Reverse" mode with reference to St2 when it is closed.

Analogue outputs Y1 and Y2 will follow the value of probe 1 with respect to St1 or St2 (with proportional-only or PID regulation), depending on the status of digital input 1.

The controller can switch from Reverse to Direct and from Direct to Reverse via summer/winter changeover from digital input and/or parameter SEa1.

INGRESSO DI1 APERTO

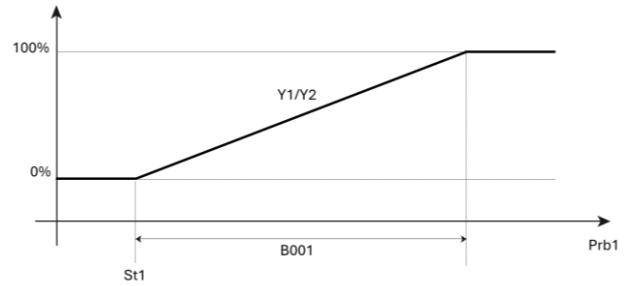
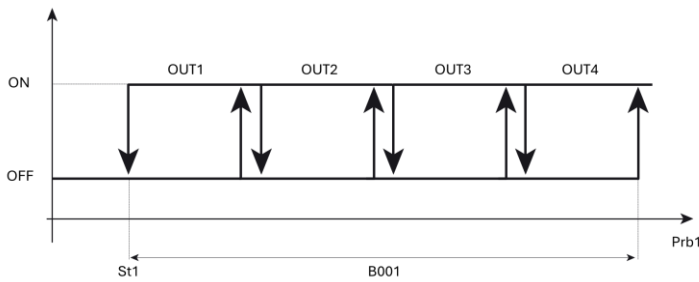

INGRESSO DI1 CHIUSO

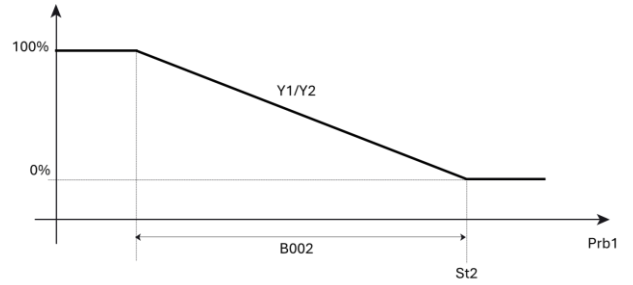
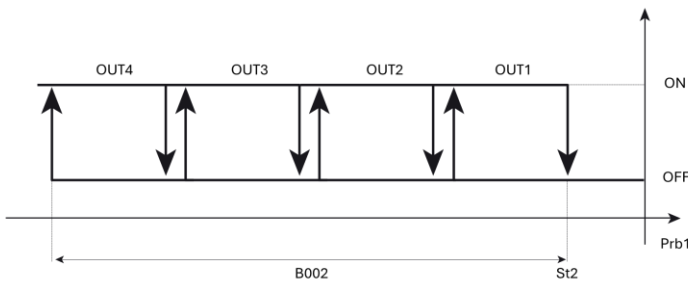

| Key         | Description             |
|-------------|-------------------------|
| St1/St2     | Set point 1/2           |
| B001        | "Direct" differential   |
| B002        | "Reverse" differential  |
| OUT 1/2/3/4 | Digital outputs 1/2/3/4 |
| Y1/Y2       | Analogue outputs 1/2    |
| Prb1        | Probe 1                 |

### 5.1.5 Mode 7: Set point and differential from DI1 (Direct) (B000=7)

The controller always works in "Direct" mode, with reference to St1 when digital input 1 is open, and with reference to St2 when it is closed.

Analogue outputs Y1 and Y2 will follow the value of probe 1 with respect to St1 or St2 (with proportional-only or PID regulation), depending on the status of digital input 1.

The controller can be switched from Direct to Reverse mode via summer/winter changeover from digital input and/or parameter SEa1.

INGRESSO DI1 APERTO

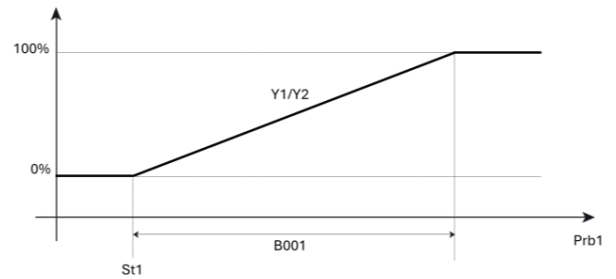
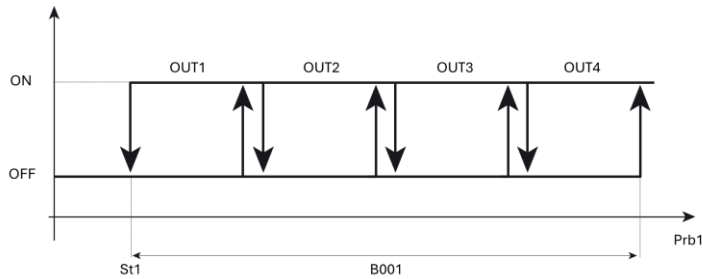

INGRESSO DI1 CHIUSO

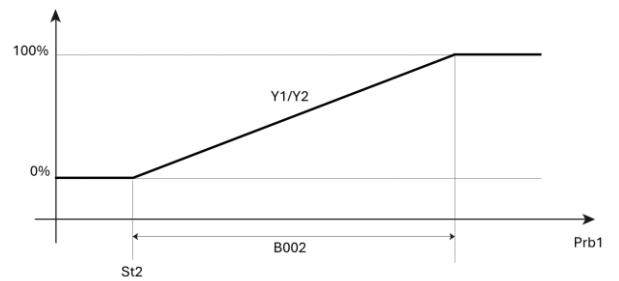
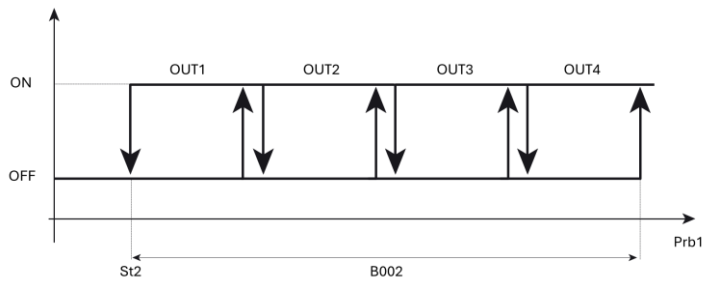

| Key         | Description               |
|-------------|---------------------------|
| St1/St2     | Set point 1/2             |
| B001        | St1 "direct" differential |
| B002        | St2 "direct" differential |
| OUT 1/2/3/4 | Digital outputs 1/2/3/4   |
| Y1/Y2       | Analogue outputs 1/2      |
| Prb1        | Probe 1                   |

### 5.1.6 Mode 8: Set point and differential from DI1 (Reverse) (B000=8)

The controller always works in "Reverse" mode, with reference to St1 when digital input 1 is open, and with reference to St2 when it is closed.

Analogue outputs Y1 and Y2 will follow the value of probe 1 with respect to St1 or St2 (with proportional-only or PID regulation), depending on the status of digital input 1.

The controller can be switched from Reverse to Direct mode via summer/winter changeover from digital input and/or parameter SEa1.

INGRESSO DI1 APERTO

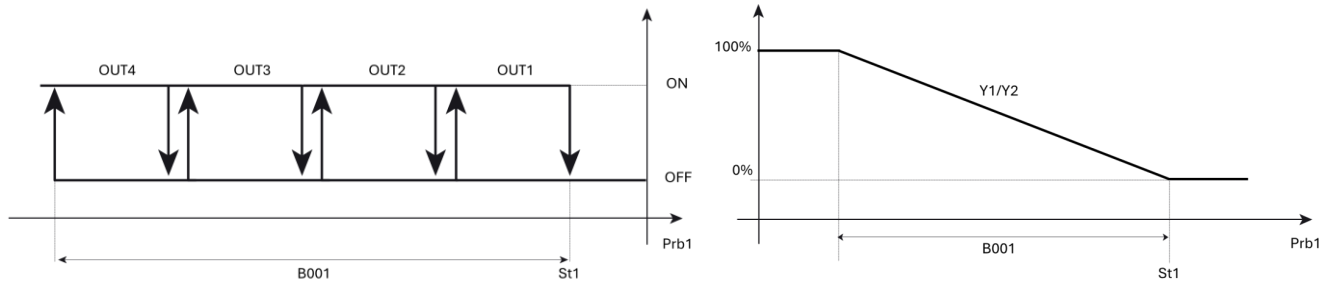

INGRESSO DI1 CHIUSO

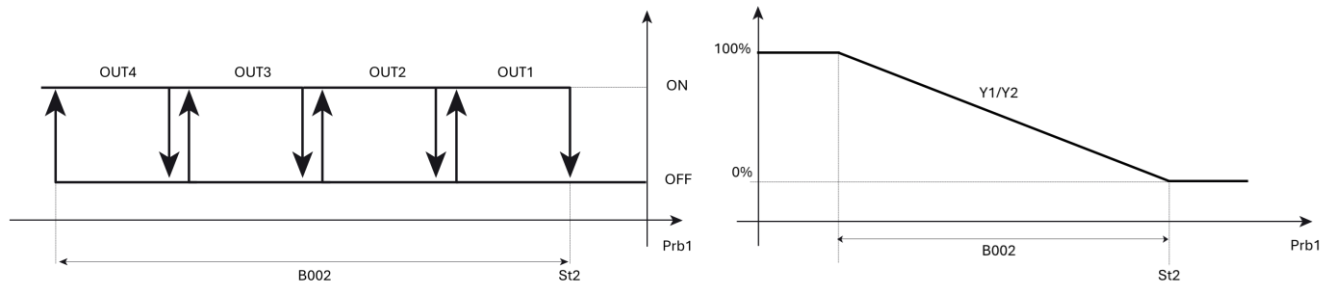

| Key         | Description                |
|-------------|----------------------------|
| St1/St2     | Set point 1/2              |
| B001        | St1 "reverse" differential |
| B002        | St2 "reverse" differential |
| OUT 1/2/3/4 | Digital outputs 1/2/3/4    |
| Y1/Y2       | Analogue outputs 1/2       |
| Prb1        | Probe 1                    |

### 5.1.7 Mode 9: Direct/reverse with two set points (B000=9)

In this operating mode, half of the outputs are active in "Direct" mode and half in "Reverse" mode.

The main feature of this mode is that there are no constraints in setting the set points for the two actions, and consequently the controller can operate as if there were two independent regulation functions based on the reading of probe 1.

Analogue output Y1 will follow the value of probe 1 during operation in "Reverse" mode, while analogue output Y2 will follow the value of probe 1 during operation in "Direct" mode (with proportional-only or PID regulation).

Season changeover is not available in this mode.

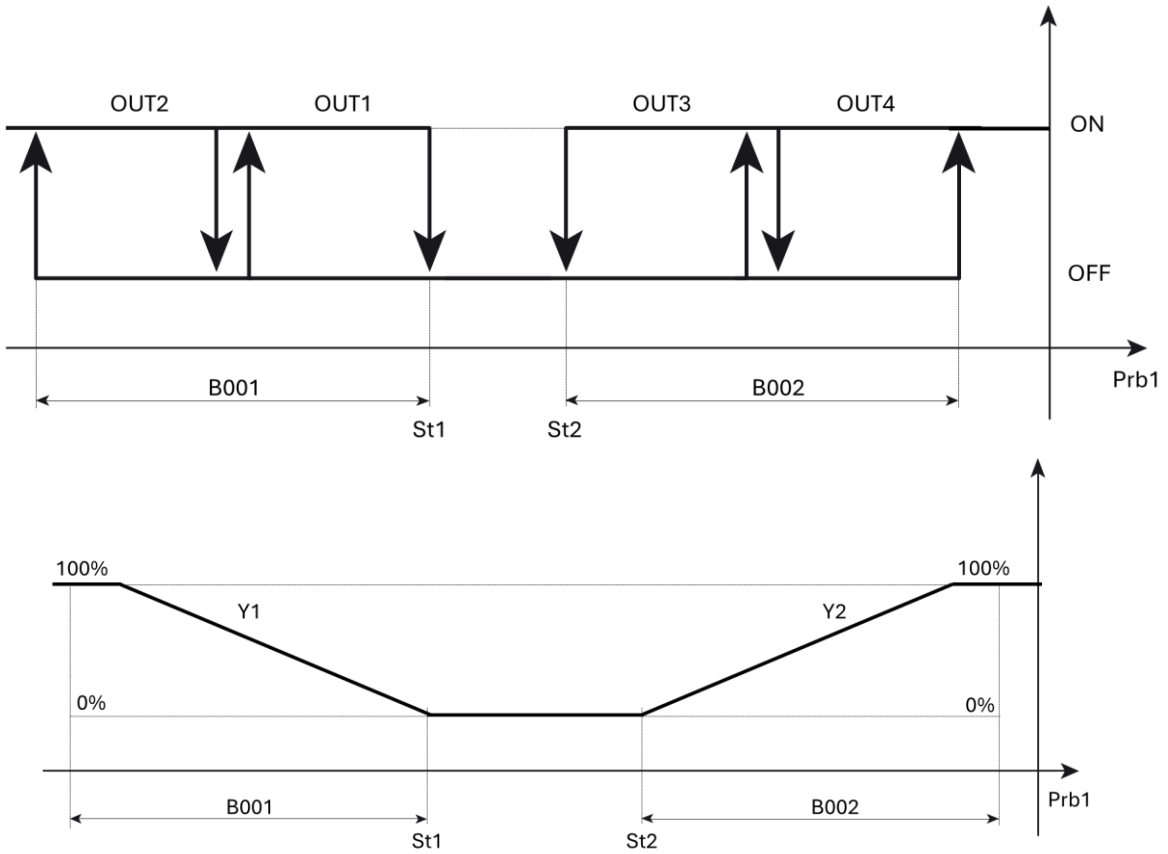

| Key         | Description                |
|-------------|----------------------------|
| St1/St2     | Set point 1/2              |
| B001        | St1 "reverse" differential |
| B002        | St2 "direct" differential  |
| OUT 1/2/3/4 | Digital outputs 1/2/3/4    |
| Y1/Y2       | Analogue outputs 1/2       |
| Prb1        | Probe 1                    |

## 5.1.8 Mode 10: 3-position valve (B000=10)

This configuration is used to regulation a tri-state floating actuator.

Unlike modulating regulation which uses 0-10 V outputs, tri-state floating regulation uses two separate digital outputs, one to regulation opening and one to regulation closing, according to the regulation request, either proportional-only or PID, as set by parameter B004.

On the Universal Controller, the tri-state actuator will be regulationled using digital output OUT1 for opening and digital output OUT2 for closing.

Outputs Y1 and Y2 will return the total request as a 0-10 V value.

The main parameters for configuring this function are as follows:

| Code | Description  | Default |
|------|--|---------|
| B100 | 3-position valve opening time 0-100%   | 60 sec  |
| B101 | Type of 3-position valve regulation request<br><i>0=Standard</i><br><i>1=Dynamic</i> | Dynamic |
| B102 | Dynamic 3-position valve regulation request reaction time                            | 10 sec  |
| B103 | Dynamic 3-position valve regulation request threshold percentage                     | 10 %    |

The valve travel time, defined by parameter B100, is used to calculate an estimate of its position as a percentage 0-100%, while parameter B101 is used to set "Dynamic" regulation type, which slows down any variations in the request by increasing or decreasing it in steps. The steps as a percentage and the delay in the variation of the request in "Dynamic" regulation mode can be set using parameters B102 and B103.

The valve opening and closing requests is calculated as per Direct regulation.

The controller can be switched to Reverse mode via summer/winter changeover from digital input and/or parameter SEa1.

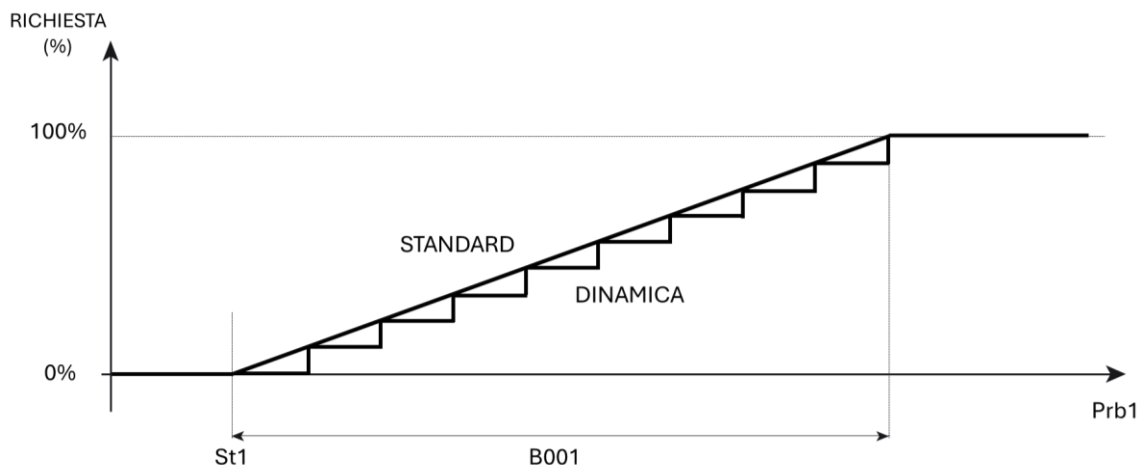

| Key      | Description   |
|----------|---|
| St1      | Set point 1   |
| B001     | Differential  |
| Prb1     | Probe 1   |
| STANDARD | Proportional or PID regulation, defined by parameter B101     |
| DYNAMIC  | Stepped regulation, defined by parameters B101, B102 and B103 |

The following sections define the different phases for regulationling the tri-state floating actuator.

## INITIALISATION

Following activation of the controller, the first phase is initialisation, during which a closing command is sent for a time equal to the setting of parameter  $B100 + 25\%$ .

This phase ensures that the next regulation phase starts with the valve in the fully-closed position (0%).

During initialisation, output OUT1 will be Off, while OUT2 will be On.

At the end of the set time, the initialisation phase will end and the valve will be ready to modulate its position based on the reading of probe 1.

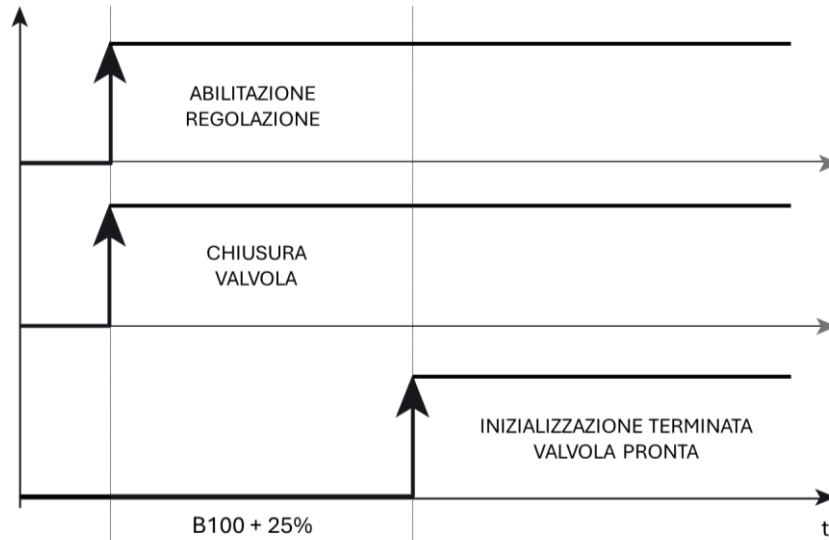

## CONTROL: OPENING

The valve opening or closing request as a percentage is defined by proportional or PID regulation (as set by parameter B004).

When the value measured by probe 1 is greater than  $St1$ , the opening request will increase until reaching maximum value defined by the threshold  $St1+B001$ . During opening, output OUT1 will be On, while OUT2 will be Off.

When the valve position reaches 100%, an alignment phase will be activated, during which an opening command is sent for a time equal to 20% of B100.

## CONTROL: CLOSING

Similarly, if the measured value starts to fall, the 3-position valve will be sent a closing request, until reaching a total closing request at  $St1$ . During closing, output OUT1 will be Off, while OUT2 will be On.

When the valve position reaches 0%, an alignment phase will be activated, during which a closing command is sent for a time equal to 20% of B100.

## CONTROL: STANDBY

In order to reduce the number of output activations, the opening and closing commands will only be sent if the request (calculated as a percentage) varies by a value greater than or equal to  $1000/B100$ , otherwise the controller remains in standby.

In standby, no actions will be applied and the OUT1 and OUT2 will remain Off.

## 5.2 Operating modes with probe 2 (Prb2)

The installation of probe 2 (input S4, terminal J3 on the controller) allows various types of auxiliary operation to be enabled based on the value read by this probe, and which are in addition to the main regulation modes "Direct", "Reverse", "Neutral zone" and "3-position valve", described in the previous paragraph.

These options can be selected via parameter B012:

| Code | Description  | Default  |
|------|--|----------|
| B012 | Probe 2 operating mode (if B000=1, 2, 3, 10):<br>0=Not used<br>1=Differential operation (Prb1-Prb2)<br>2=Reserved<br>3=Reserved<br>4=Reserved<br>5=Enable regulation based on absolute set point<br>6=Enable regulation based on set point differential<br>7=Independent operation (circ.1 + circ.2)<br>8=Control on higher probe value<br>9=Control on lower probe value<br>10=Control set point from probe 2<br>11=Automatic summer/winter changeover from probe 2 | Not used |

### 5.2.1 Differential operation (Prb1-Prb2) (B012=1)

Control is carried out by comparing the set point St1 against the difference between the values read by the two probes (Prb1-Prb2) instead of just the value of probe Prb1.

In practice, the regulation aims to bring the difference Prb1-Prb2 to the value St1.

"Direct" operation (B000=1) shown in the example aims to reduce the difference Prb1-Prb2, that is tending to increase.

"Reverse" operation (B000=2), on the other hand, aims to reduce the difference Prb1-Prb2 that is tending to decrease.

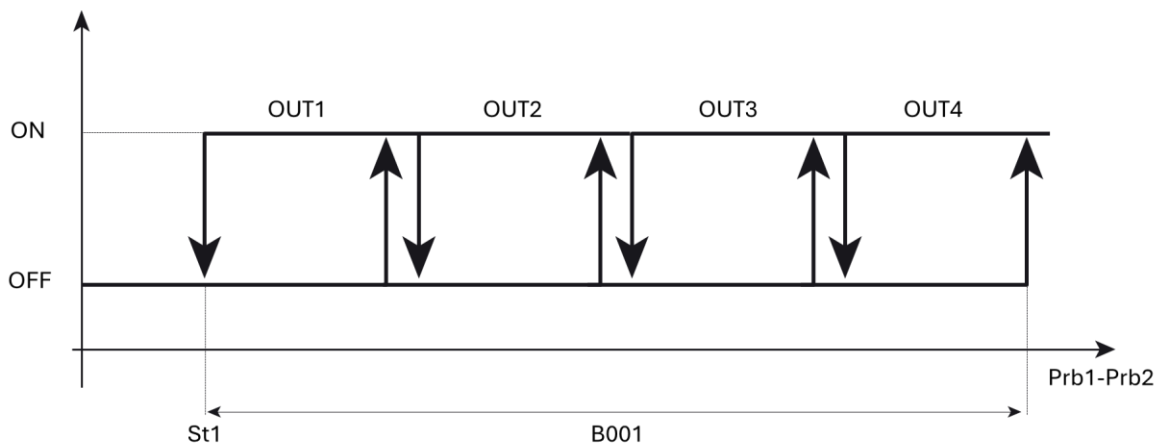

| Key         | Description             |
|-------------|-------------------------|
| St1         | Set point 1             |
| B001        | Differential            |
| OUT 1/2/3/4 | Digital outputs 1/2/3/4 |
| Prb1        | Probe 1                 |
| Prb2        | Probe 2                 |

### 5.2.2 Enable regulation based on absolute set point (B012=5)

If B012=5, the value of probe 2 is used as the logic to enable the main regulation mode, Direct or Reverse.

If the value read by probe 2 is between the threshold value B022+B021 and the threshold value B023+B021, the main regulation mode, Direct or Reverse, will be activated.

Otherwise, if the value read by probe 2 is lower than the value of parameter B022 or higher than the value of parameter B023, the main regulation mode, Direct or Reverse, will be deactivated.

This operation is not available in "Neutral zone" mode (B000 = 3).

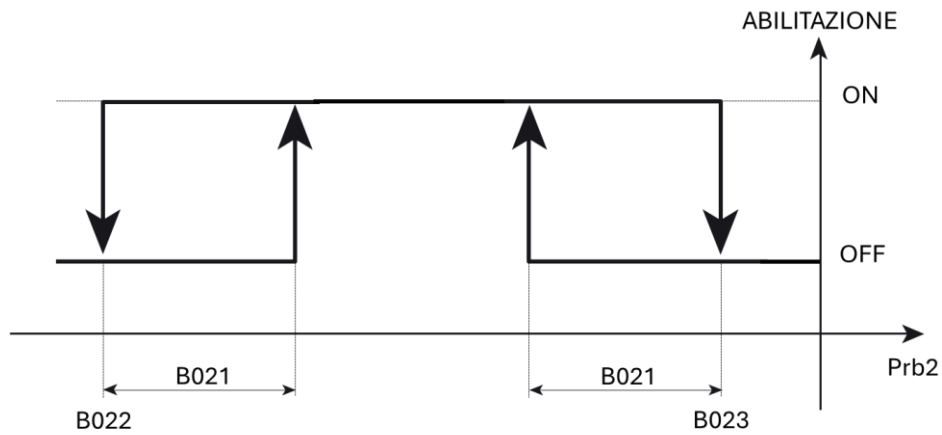

| Key  | Description   |
|------|---|
| B021 | Logical differential on absolute set point from probe 2 |
| B022 | Start threshold on absolute set point from probe 2      |
| B023 | End threshold on absolute set point from probe 2        |
| Prb2 | Probe 2   |

### 5.2.3 Enable regulation based on set point differential (B012=6)

Unlike enable regulation on absolute set point, when B012=6 the difference between probe 2 and probe 1 is used to enable the main regulation, Direct or Reverse.

If the difference between the readings of the two probes is between the threshold value B022+B021 and the threshold value B023+B021, the main regulation mode, Direct or Reverse, will be activated.

Otherwise, if the difference is less than the value of parameter B022 or greater than the value of parameter B023, the main regulation mode, Direct or Reverse, will be deactivated.

This operation is not available in "Neutral zone" mode (B000 = 3).

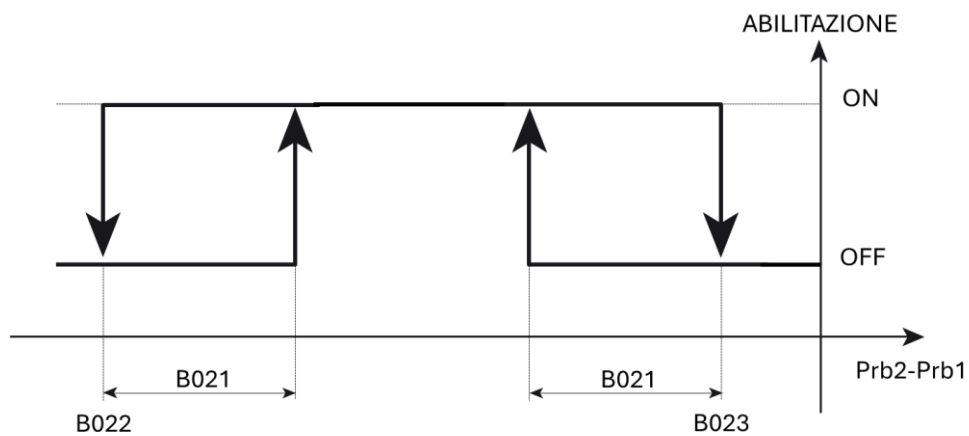

| Key  | Description   |
|------|---|
| B021 | Logical differential on set point differential from probe 2 |
| B022 | Start threshold on set point differential from probe 2      |
| B023 | End threshold on set point differential from probe 2        |
| Prb2 | Probe 2   |

## 5.2.4 Independent operation (circuit 1 + circuit 2) (B012=7)

By setting B012=7, the controller manages two independent circuits, called circuit 1 and circuit 2, each with its own set point (St1, St2), differential (B001, B002), digital outputs, analogue outputs and regulation probes.

For the main regulation modes (defined by parameter B000), Direct, Reverse or 3-position valve, the type of regulation can be switched via summer/winter changeover from digital input or managed independently for circuit 1 and circuit 2, using parameters SEa1 and SEa2 respectively.

The association of the outputs during independent operation is shown below:

| Description output | Direct (B000=1)       | Reverse (B000=2)      | Neutral zone (B000=3) | 3-position valve (B000=10) |
|--------------------|-----------------------|-----------------------|-----------------------|----------------------------|
| OUT1               | Output 1<br>Circuit 1 | Output 1<br>Circuit 1 | Output 1<br>Circuit 1 | Circuit 1 valve opening    |
| OUT2               | Output 2<br>Circuit 1 | Output 2<br>Circuit 1 | Output 1<br>Circuit 2 | Circuit 1 valve closing    |
| OUT3               | Output 1<br>Circuit 2 | Output 1<br>Circuit 2 | Output 2<br>Circuit 1 | Circuit 2 valve opening    |
| OUT4               | Output 2<br>Circuit 2 | Output 2<br>Circuit 2 | Output 2<br>Circuit 2 | Circuit 2 valve closing    |
| Y1                 | Request<br>Circuit 1  | Request<br>Circuit 1  | Request<br>Circuit 1  | Request<br>Circuit 1       |
| Y2                 | Request<br>Circuit 2  | Request<br>Circuit 2  | Request<br>Circuit 2  | Request<br>Circuit 2       |

The example shows “Neutral zone” mode (B000=3):

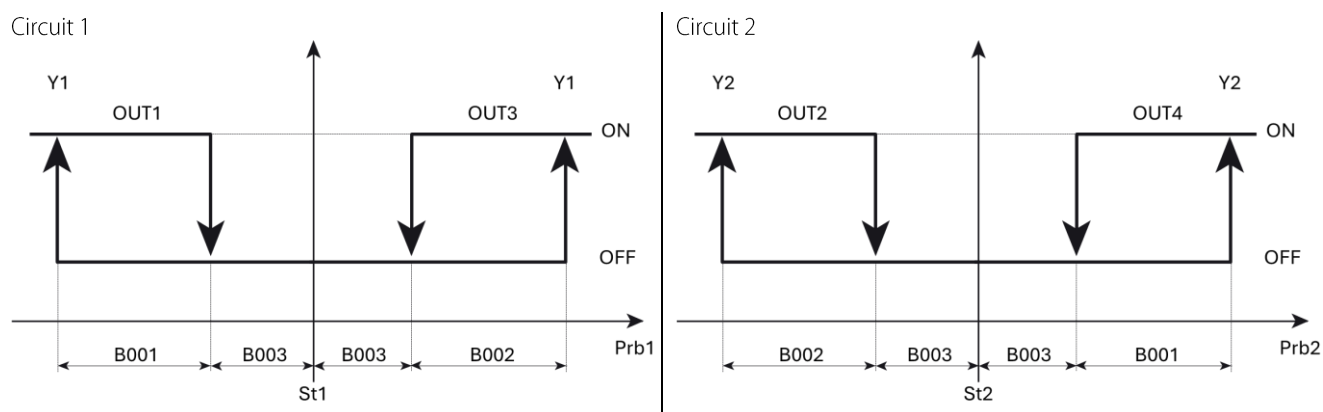

| Key         | Description               |
|-------------|---------------------------|
| St1         | Set point 1               |
| B001        | Set point 1 differential  |
| St2         | Set point 2               |
| B002        | Set point 2 differential  |
| B003        | Neutral zone differential |
| OUT 1/2/3/4 | Digital outputs 1/2/3/4   |
| Y1/Y2       | Analogue outputs 1/2      |
| Prb1        | Probe 1                   |
| Prb2        | Probe 2                   |

### 5.2.5 Control on the higher probe value (B012=8)

By setting B012=8, the probe used for regulation and therefore activation of the outputs is, at any given moment, the one that measures the higher value, between probe 1 and probe 2.

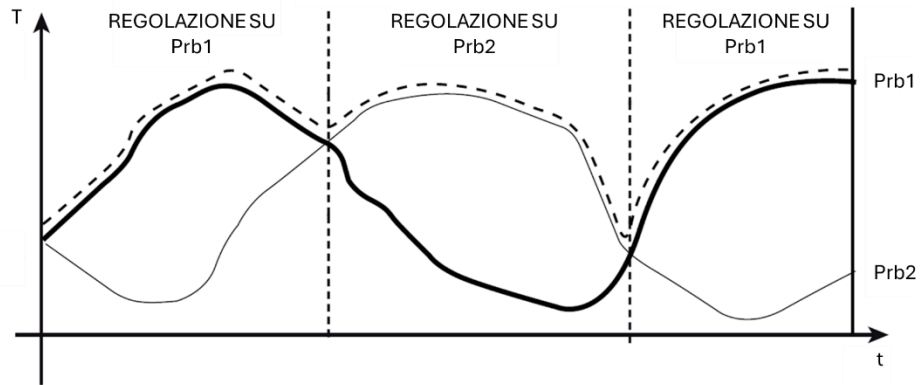

| Key  | Description |
|------|-------------|
| Prb1 | Probe 1     |
| Prb2 | Probe 2     |

### 5.2.6 Control on the lower probe value (B012=9)

By setting B012=9, the probe used for regulation and therefore activation of the outputs is, at any given moment, the one that measures the lower value, between probe 1 and probe 2.

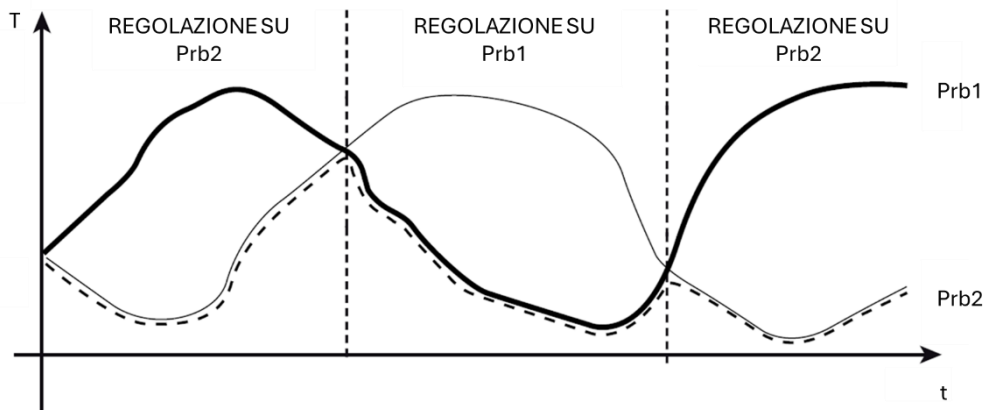

| Key  | Description |
|------|-------------|
| Prb1 | Probe 1     |
| Prb2 | Probe 2     |

### 5.2.7 Set point on probe 2 (B012=10)

If B012=10, the regulation set point is no longer fixed, but will refer to the value read by probe 2.

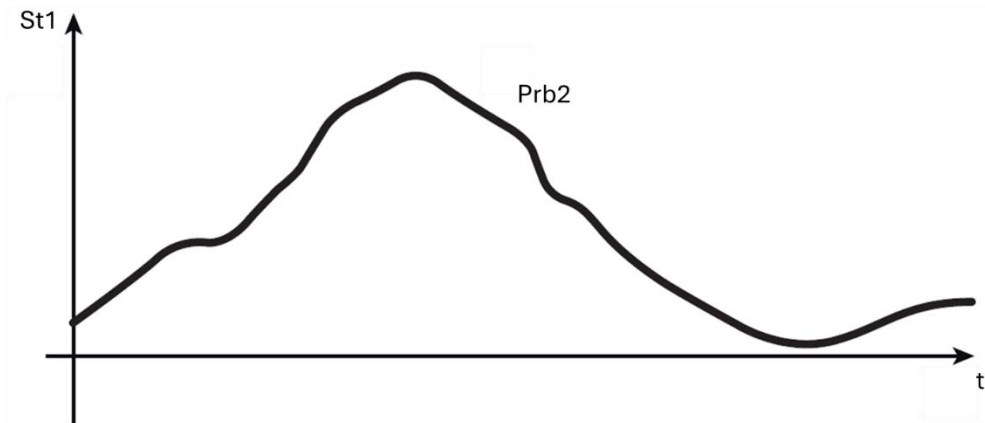

| Key  | Description |
|------|-------------|
| St1  | Set point 1 |
| Prb2 | Probe 2     |

### 5.2.8 Automatic summer/winter changeover from probe 2 (B012=11)

If B012=11, when the value of probe 2 is lower than B022, regulation will be based on parameters St1 and B001 and the Direct or Reverse mode setting defined by B000 (if B000 = 10, Direct regulation mode will be active).

If the value of probe 2 is within the range between B022 and B023, the controller will enter standby mode, and any active or modulating outputs due to the main regulation mode will be deactivated.

When the value of probe 2 is higher than B023, the set point and differential will automatically switch to St2 and B002 respectively, while the regulation logic will be the opposite of what has been set for B000 (if of B000 = 10, Reverse regulation mode will be active).

This operation is not available in "Neutral zone" mode (B000 = 3).

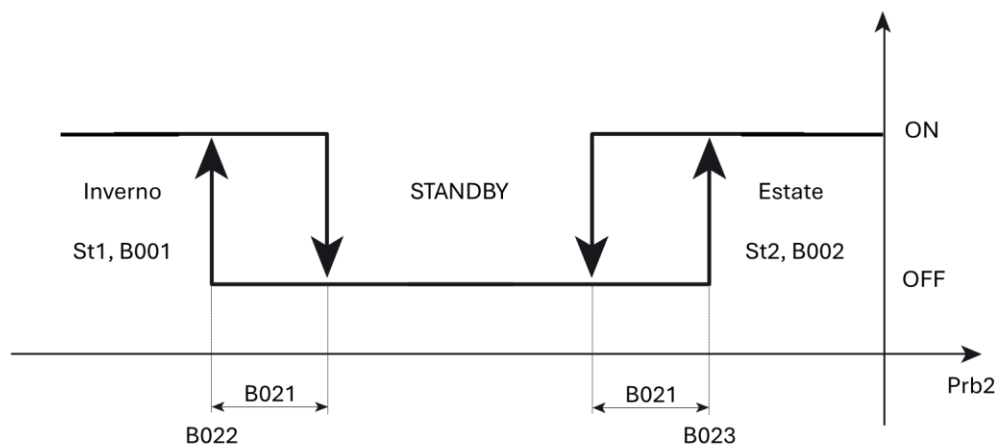

| Key     | Description   |
|---------|---|
| St1     | Set point 1   |
| B001    | Set point 1 differential                            |
| St2     | Set point 2   |
| B002    | Set point 2 differential                            |
| B021    | Season changeover logical differential from probe 2 |
| B022    | Season changeover start threshold from probe 2      |
| B023    | Season changeover end threshold from probe 2        |
| ON, OFF | Main regulation status                              |
| STANDBY | Standby zone  |
| Prb2    | Probe 2   |

## 5.3 Probe 3 functions (B036)

The installation of probe 3 (input S5, terminal J2 on the controller) allows various auxiliary functions to be enabled as compensation of the main regulation modes "Direct", "Reverse", "Neutral zone" and "3-position valve" (described in paragraph 5.1).

These options can be selected via parameter B036:

| Code | Description  | Default  |
|------|--|----------|
| B036 | Probe 3 function (if B000=1, 2, 3, 10):<br>0=Disabled<br>1=Summer compensation<br>2=Winter compensation<br>3=Summer/winter compensation<br>4=Read only (valid for any value of B000) | Disabled |

### 5.3.1 Summer compensation (B036=1)

If B036=1, the value read by probe 3 is used to calculate and apply an offset to the current set point, in order to compensate for the action of the main regulation in summer.

The offset is calculated proportionally between an initial threshold (parameter B024) and an end threshold (parameter B025):

- At and below the initial threshold, the offset will be zero.
- At and above the end threshold, the offset will be equal to the value set for parameter B026.
- For probe 3 values between the initial threshold and the end threshold, the offset is calculated proportionally between the null value and the value defined by parameter B026.

Therefore, if parameter B026 is set to a value greater than 0, the offset will be positive. Similarly, if parameter B026 is set to a value less than 0, the offset will be negative.

This mode can be used with the standard Direct, Reverse, Neutral Zone and 3-Point Valve modes.

Summer compensation can also be activated with special operating modes (B000=0), provided that the special mode selected is "regulation on St1 and B001" or "regulation on St2 and B002".

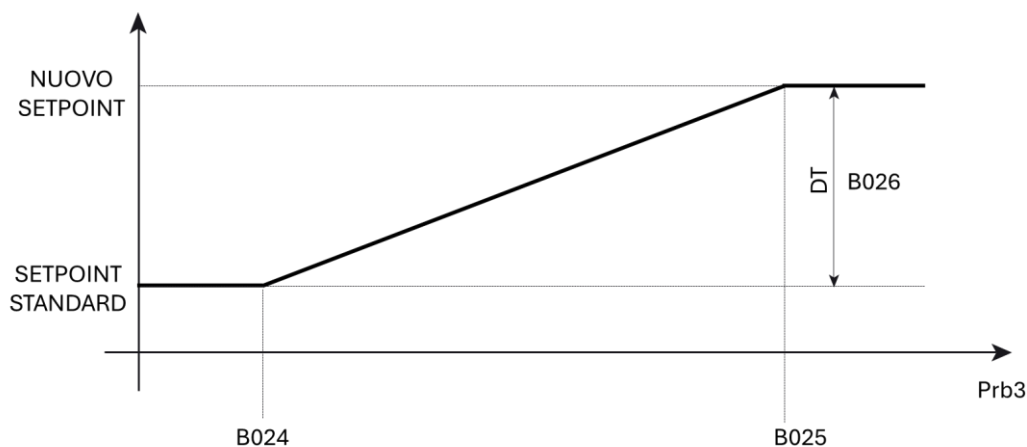

| Key                | Description                                 |
|--------------------|---|
| B024               | Summer compensation start value             |
| B025               | Summer compensation end value               |
| B026               | Maximum summer compensation value           |
| NEW SET POINT      | Control set point with offset equal to B026 |
| STANDARD SET POINT | Control set point with null offset          |
| Prb3               | Probe 3                                     |

### 5.3.2 Winter compensation (B036=2)

Similarly to summer compensation, if B036=2 the value read by probe 3 is used to calculate and apply an offset to the set point in use to compensate for the action of the main regulation in winter.

The offset is calculated proportionally between an initial threshold (parameter B027) and an end threshold (parameter B028):

- At and below the initial threshold, the offset will be zero.
- At and above the end threshold, the offset will be equal to the value set for parameter B028.
- For probe 3 values between the initial threshold and the end threshold, the offset is calculated proportionally between the null value and the value defined by parameter B028.

Therefore, if parameter B028 is set to a value greater than 0, the offset will be positive.

Similarly, if parameter B028 is set to a value less than 0, the offset will be negative.

This mode can be used with the standard Direct, Reverse, Neutral Zone and 3-Point Valve modes.

Winter compensation can also be activated with special operating modes (B000=0), provided that the special mode selected is "regulation on St1 and B001" or "regulation on St2 and B002".

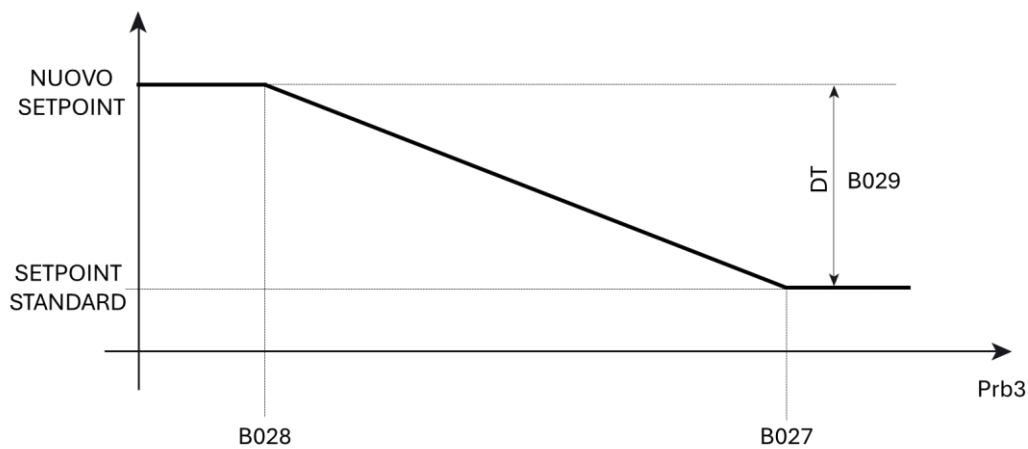

| Key                | Description                                 |
|--------------------|---|
| B027               | Winter compensation start value             |
| B028               | Winter compensation end value               |
| B029               | Maximum winter compensation value           |
| NEW SET POINT      | Control set point with offset equal to B029 |
| STANDARD SET POINT | Control set point with null offset          |
| Prb3               | Probe 3                                     |

### 5.3.3 Summer/winter compensation (B036=3)

The compensation calculated when B036=3 is the combined action of the summer and winter compensation, in order to adapt the main regulation to different probe 3 readings during the two seasons.

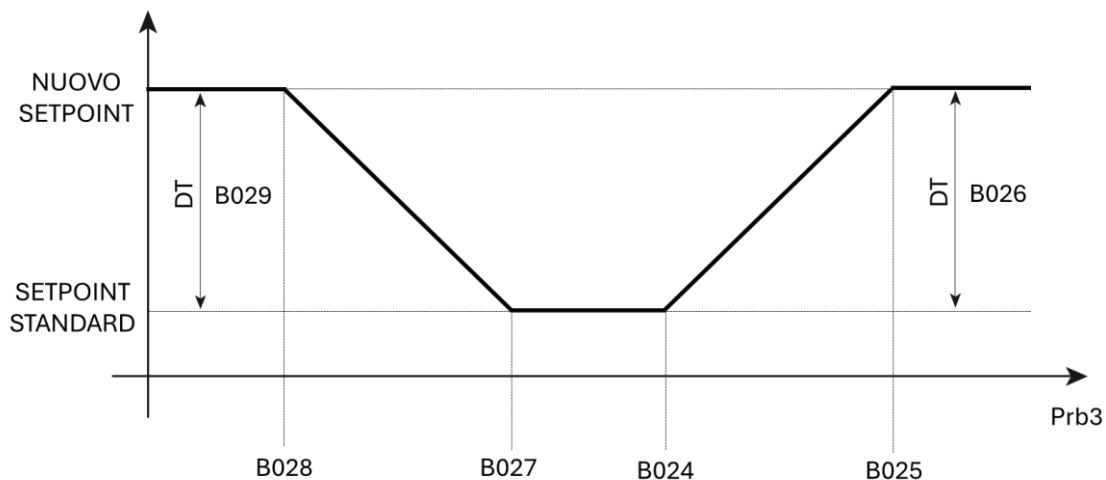

| Key                | Description   |
|--------------------|---|
| B024               | Summer compensation start value                     |
| B025               | Summer compensation end value                       |
| B026               | Maximum summer compensation value                   |
| B027               | Winter compensation start value                     |
| B028               | Winter compensation end value                       |
| B029               | Maximum winter compensation value                   |
| NEW SET POINT      | Control set point with offset equal to B026 or B029 |
| STANDARD SET POINT | Control set point with null offset                  |
| Prb3               | Probe 3   |

### 5.3.4 Read-only (B036=4)

The value read by probe 3 will be shown on the display, in Applica and via the supervisor, however no additional actions are performed. This function can be enabled for any type of main and auxiliary regulation.

## 5.4 Special operation (B000=0)

If parameter B000 is set to value 0=Special operation, a custom operating logic can be created that allows the regulation logic of each individual regulation output to be configured using additional parameters, known as special parameters, which will be available in the "Control configuration" menu.

These parameters are:

- Control type
  - o Control on thresholds
  - o Control on St1 and B001
  - o Control on St2 and B002
  - o Alarm status
  - o Unit status ON/OFF
  - o Control status ON/OFF
- Control probe
  - o Probe 1
  - o Probe 2
  - o Probe 1/probe 2 from DI1
  - o Probe 1 - probe 2
  - o Probe 2 - probe 1
- Activation value/request at 100%
- Deactivation value/request at 0%
- Output mode
  - o Direct
  - o Reverse
  - o Direct/reverse from summer/winter
- Alarm dependency (On-Off outputs only)
  - o Global alarm
  - o Alarm on probe 1/circuit 1
  - o Alarm on probe 2/circuit 2
  - o Alarm on probe 3
  - o High alarm on probe 1
  - o Low alarm on probe 1
  - o High alarm on probe 2
  - o Low alarm on probe 2
  - o High alarm on probe 3
  - o Low alarm on probe 3
- Control type (for On-Off output only)
  - o On/Off
  - o 3-position valve opening
  - o 3-position valve closing

### Special parameters and correspondence with the different outputs

|                          | NO1  | NO2  | NO3  | NO4  | Y1   | Y2   |
|--------------------------|------|------|------|------|------|------|
| Control type             | Ba01 | Ba08 | Ba15 | Ba22 | Ba30 | Ba40 |
| Control probe            | Ba02 | Ba09 | Ba16 | Ba23 | Ba31 | Ba41 |
| Activation value         | Ba03 | Ba10 | Ba17 | Ba24 |      |      |
| Request at 100%          |      |      |      |      | Ba32 | Ba42 |
| Deactivation value       | Ba04 | Ba11 | Ba18 | Ba25 |      |      |
| Request at 0%            |      |      |      |      | Ba33 | Ba33 |
| Output mode              | Ba05 | Ba12 | Ba19 | Ba26 | Ba34 | Ba44 |
| Alarm dependency         | Ba06 | Ba13 | Ba20 | Ba27 |      |      |
| On-Off output regulation | Ba07 | Ba14 | Ba21 | Ba28 |      |      |

Please see paragraph 6.4.2 for further details.

#### Notice:

- The override settings via C001, C002, C020 and C021 only apply to outputs NO\* and Y\* that have the "Control type on NO\* output and "Control type on Y\* output" set to a value  $\neq 0$ .
- The "Alarm dependency for NO\* activation" can only be set if the "Control type on NO\* output" is set as "Alarm status".
- The regulation parameters that are valid for "3-position valve" mode are set for output NO1, for the regulation of valve 1, and those set for output NO3 for the regulation of valve 2. However, Ba08 and Ba22 need to be set to a value  $\neq 0$ .
- "3-position valve" mode will use outputs NO1-NO2 for the regulation of valve 1 and outputs NO3-NO4 for the regulation of valve 2. It will be possible to set which output to use for the opening command and which for the closing command.
- If the output rotation function is active, the regulation type, activation value and deactivation value parameters referring to NO1, NO2, NO3 and NO4 will be decoupled from the respective digital output and will be reassigned according to the activation/deactivation order calculated based on the operating hours of each digital output.

## 5.5 Scheduler

The Universal Controller offers the possibility to enable a scheduler. Three different profiles can be programmed:

- COMFORT
- ECONOMY
- OFF

The economy and comfort profiles have different regulation set points.

| Code | Description                 | Default |
|------|-----------------------------|---------|
| St1  | Set point 1                 | 20.0    |
| St2  | Set point 2                 | 40.0    |
| St1e | Set point 1 in economy mode | 15.0    |
| St2e | Set point 2 in economy mode | 35.0    |

There are also different summer and winter compensation thresholds:

| Code | Description                                 | Default |
|------|---|---------|
| B024 | Summer compensation start value             | 35.0    |
| B025 | Summer compensation end value               | 45.0    |
| B026 | Maximum summer compensation value           | 5.0     |
| B027 | Winter compensation start value             | 15.0    |
| B028 | Winter compensation end value               | 0.0     |
| B029 | Maximum winter compensation value           | 5.0     |
| B030 | Summer compensation start value (economy)   | 35.0    |
| B031 | Summer compensation end value (economy)     | 45.0    |
| B032 | Maximum summer compensation value (economy) | 5.0     |
| B033 | Winter compensation start value (economy)   | 15.0    |
| B034 | Winter compensation end value (economy)     | 0.0     |
| B035 | Maximum winter compensation value (economy) | 5.0     |

The off profile, on the other hand, switches the unit to “Off from scheduler” status.

Up to three programs can be set (P1, P2 and P3), each with four daily time bands.

Each time band can be enabled and the desired start time and profile can be selected. The set profile will then remain active until the start of the next time band.

For each day of the week, the operating mode can be selected between:

- COMFORT
- ECONOMY
- OFF
- Program 1 (P1)
- Program 2 (P2)
- Program 3 (P3)

Below is an example of switching from the off profile to economy and then comfort:

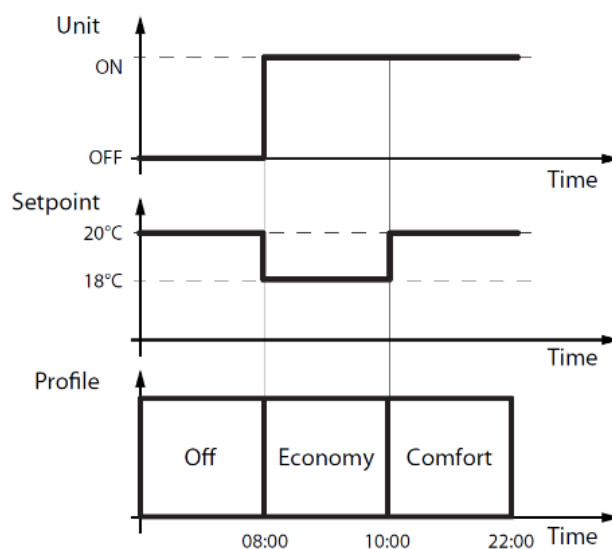

If selecting off, economy or comfort, the selected profile will remain active for the entire day, from 00:00 to 23:59.

If selecting P1, P2 or P3, the set daily program will be active.

The default is:

- P1 used as the Monday to Thursday program
- P2 used as the Friday program
- P3 used as the weekend program (Saturday and Sunday).

P1 (weekday program) has two time bands:

- At 08:00 the comfort profile starts
- At 22:00 the economy profile starts

P2 (Friday weekday program) has two time bands:

- At 08:00 the comfort profile starts
- At 22:00 the off profile starts.

P3 (weekend program) has two time bands:

- At 08:00 the economy profile starts
- At 22:00 the off profile starts.

The scheduler also allows a vacation period to be set, specifying the day and month the vacation period starts/ends and the operating mode that will be applied during this period.

*Please see paragraph 6.7 for further details.*

## 5.6 Soft start

The soft start function allows the set point to be increased or decreased when regulation starts based on the value set for parameter B072.

The function is useful if the controller is used in applications where switching on at full load could be incompatible with the regulationed process.

The soft start function is applied at the start of regulation for a set time (in seconds) via parameter B071. Setting the value of parameter B071 to zero disables the function.

Parameter B073 applies to circuit 2 if independent operation is active.

| Code | Description   | Default |
|------|---|---------|
| B071 | Soft start time on starting regulation. Set 0 to disable. | 0 sec   |
| B072 | St1 during soft start                                     | 20.0    |
| B073 | St2 during soft start                                     | 40.0    |

Example:

assuming that the set point (St1) is 30.0 with a differential (B001) of 2.0 and that the regulation probe measures 20.0.

By setting B071 to 120 seconds and B072 to 20.0, when Reverse regulation is activated (B000=2), the regulation set point will be 20.0 for 2 minutes.

After 2 minutes, the regulation set point changes to the value set for parameter St1, therefore 30.0, and will remain at that value until the regulation request is null, deactivating regulation. The next time regulation is reactivated, the soft start function starts again.

## 5.7 Output rotation

The rotation function changes the on and off priority of the on/off regulation outputs.

| Code | Description   | Default |
|------|---|---------|
| B011 | Output rotation (if B000=0,1, 2, 7, or 8)<br>0=Rotation not active<br>1=Standard rotation | 0       |

With standard rotation, in relation to the regulation request, the output that has been active for the longest time is deactivated, or the output that has been inactive for the longest time is activated.

For outputs with the same number of operating hours, the same activation and deactivation sequence used when B011=0 will be applied, rotation not active, i.e. LIFO (last in first out).

# 6. PARAMETER TABLE

**Notice:**

Parameter setting access levels: U=User; S=Service; M=Manufacturer;  
 R/W=read/write parameters; R=read-only parameters;  
 Modbus: HR=Holding register; IR=Analogue input; CS=Coil status; DI=Digital input; (2R)=32 bit register;

**IMPORTANT:**

Not all the parameters listed below will be displayed when scrolling through the display interface; enabling a specific configuration may mean parameters are displayed that were previously hidden.

**Example:**

- The operating status and parameters relating to circuit 2 will be displayed only if independent operation is selected,
- Economy mode status and parameters will only be displayed if there are active time bands.

The display therefore depends on what has been configured.

## 6.1 Main page (press DOWN briefly)

| User | Code  | Description  | Def. | Min. | Max. | UOM | R/W | Modbus                                   |
|------|---|--|------|------|------|-----|-----|--|
| U    | On ----<br>Unit on<br>OFF ALrM<br><br>OFF bMS<br>OFF Schd<br>OFF dl<br>OFF diSP | Unit operating status<br><i>0=Waiting</i><br><i>1=Unit ON</i><br><i>2=OFF from alarm</i><br><i>3=Reserved</i><br><i>4=OFF from BMS</i><br><i>5=OFF from scheduler</i><br><i>6=OFF from DI</i><br><i>7=OFF from display</i> |      | 0    | 7    |     | R   | IR 3000                                  |
| U    | SEaS  | Season<br><i>0=Summer</i><br><i>1=Winter</i>   |      | 0    | 1    |     | R   | CS 2005                                  |
| U    | rEGt  | Control probe reading  |      |      |      |     | R   | IR 3002                                  |
| U    | rSt1  | Control set point 1  |      |      |      |     | R   | IR 3003                                  |
| U    | rSt2  | Control set point 2  |      |      |      |     | R   | IR 3004                                  |
| U    | Prb1  | Probe 1 reading  |      |      |      |     | R   | IR 0001                                  |
| U    | Prb2  | Probe 2 reading  |      |      |      |     | R   | IR 0002                                  |
| U    | Prb3  | Probe 3 reading  |      |      |      |     | R   | IR 0003                                  |
| U    | din1  | Digital input 1 reading  |      |      |      |     | R   | DI 0005                                  |
| U    | din2  | Digital input 2 reading  |      |      |      |     | R   | DI 0006                                  |
| U    | do  | Relay status<br><i>Relay 1</i><br><i>Relay 2</i><br><i>Relay 3</i><br><i>Relay 4</i>   |      | -    | 4    |     | R   | DI 0000<br>DI 0001<br>DI 0002<br>DI 0003 |
| U    | dou5  | Relay 5 status   |      | 0    | 1    |     | R   | DI 0004                                  |
| U    | Y1  | Analogue output 1 %  |      | 0    | 100  | %   | R   | IR 0226                                  |
| U    | Y2  | Analogue output 2 %  |      | 0    | 100  | %   | R   | IR 0227                                  |
| U    | 000 000h  | Unit operating hours   |      |      |      | h   | R   | IR 3018 (2R)                             |
| U    | 000 000h1   | Output 1 operating hours   |      |      |      | h   | R   | IR 3020 (2R)                             |
| U    | 000 000h2   | Output 2 operating hours   |      |      |      | h   | R   | IR 3022 (2R)                             |
| U    | 000 000h3   | Output 3 operating hours   |      |      |      | h   | R   | IR 3024 (2R)                             |
| U    | 000 000h4   | Output 4 operating hours   |      |      |      | h   | R   | IR 3026 (2R)                             |
| U    | rEL   | Firmware version   |      |      |      |     | R   | IR 3028                                  |
| U    | dAY   | Day  |      | 1    | 31   |     | R   | IR 8000                                  |
| U    | Mont  | Month  |      | 1    | 12   |     | R   | IR 8001                                  |
| U    | YEAr  | Year   |      | 0    | 99   |     | R   | IR 8002                                  |
| U    | UdAY  | Day of the week<br><i>0=Sunday</i><br><i>1=Monday</i><br><i>2=Tuesday</i><br><i>3=Wednesday</i><br><i>4=Thursday</i><br><i>5=Friday</i><br><i>6=Saturday</i>   |      | 0    | 6    |     | R   | IR 8005                                  |
| U    | Hour  | Hours  |      | 0    | 59   |     | R   | IR 8003                                  |
| U    | Min   | Minutes  |      | 0    | 59   |     | R   | IR 8004                                  |

## 6.2 Main page (press PRG briefly)

| User | Code | Description                                  | Def. | Min. | Max. | UOM | R/W | Modbus  |
|------|------|--|------|------|------|-----|-----|---------|
| U    | UnSt | Set unit on/off from keypad<br>0=Off<br>1=On | 0    | 0    | 1    |     | R   | CS 0035 |
| U    | St1  | Set point 1                                  | 20   | B013 | B014 |     | R   | HR 0003 |
| U    | St2  | Set point 2                                  | 40   | B015 | B016 |     | R   | HR 0004 |
| U    | St1E | Set point 1 in economy mode                  | 15   | B013 | B014 |     | R   | HR 2003 |
| U    | St2E | Set point 2 in economy mode                  | 35   | B015 | B016 |     | R   | HR 2004 |
| U    | SEa1 | Circuit 1 season<br>0=Summer<br>1=Winter     | 0    | 0    | 1    |     | R   | CS 2005 |
| U    | SEa2 | Circuit 2 season<br>0=Summer<br>1=Winter     | 0    | 0    | 1    |     | R   | CS 2006 |

## 6.3 Input/output configuration

| User | Code | Description   | Def. | Min. | Max. | UOM   | R/W | Modbus  |
|------|------|---|------|------|------|-------|-----|---------|
| S    | Io01 | Probe 1 type<br>0=NTC<br>1=NTC HT<br>2= PT1000<br>3=Reserved<br>4=0-10 Vdc<br>5=0 to 5 Vdc ratiometric<br>6=0-20 mA<br>7=4-20 mA  | 0    | 0    | 7    |       | R/W | HR 4000 |
| S    | Io02 | Minimum value of probe 1 (current or voltage)   | 0    | -199 | Io03 |       | R/W | HR 4001 |
| S    | Io03 | Maximum value of probe 1 (current or voltage)   | 100  | Io02 | 999  |       | R/W | HR 4002 |
| S    | Io04 | Probe 1 calibration   | 0    | -179 | 179  | Delta | R/W | HR 4003 |
| S    | Io05 | Probe 1 noise filter<br>0=Value without any sample<br>(faster measurement)<br>1=Value after 3 samples<br>2=Value after 6 samples<br>3=Value after 9 samples<br>4=Value after 14 samples<br>5=Value after 26 samples<br>6=Value after 46 samples<br>7=Value after 85 samples<br>8=Value after 155 samples<br>9=Value after 255 samples<br>(slower measurement) | 5    | 0    | 9    |       | R/W | HR 4004 |
| S    | Io06 | Probe 2 type<br>0=NTC<br>1=NTC HT<br>2=0 to 5 Vdc ratiometric<br>3=0-20 mA<br>4=4-20 mA   | 0    | 0    | 4    |       | R/W | HR 4005 |
| S    | Io07 | Minimum value of probe 2 (current or voltage)   | 0    | -199 | Io08 |       | R/W | HR 4006 |
| S    | Io08 | Maximum value of probe 2 (current or voltage)   | 100  | Io07 | 999  |       | R/W | HR 4007 |
| S    | Io09 | Probe 2 calibration   | 0    | -179 | 179  | Delta | R/W | HR 4008 |
| S    | Io10 | Probe 2 noise filter (see Io05)   | 5    | 0    | 9    |       | R/W | HR 4009 |

|   |      |  |     |      |      |       |     |         |
|---|------|--|-----|------|------|-------|-----|---------|
| S | lo11 | Input DI1 configuration<br>(If B000≠6, 7, 8 and if B000=0 with regulation probe≠2: Probe 1/probe 2 from DI1)<br>0=Input not active<br>1=Serious alarm Automatic reset (circ.1)<br>2=Serious alarm Manual reset (circ.1)<br>3=Delayed serious alarm Manual reset (circ.1)<br>4=Unit ON/OFF input<br>5=Reserved<br>6=Reserved<br>7=Delayed signal-only alarm<br>8=Signal-only alarm<br>9=Serious alarm Automatic reset (circ.2)<br>10=Serious alarm Manual reset (circ.2)<br>11=Delayed serious alarm Manual reset (circ.2)<br>12=Reserved<br>13=Summer/winter (not valid for B000=3, 9) | 0   | 0    | 13   |       | R/W | HR 4010 |
| S | lo12 | Input DI1 logic<br>0=NC<br>1=NO  | 1   | 0    | 1    |       | R/W | CS 4011 |
| S | lo13 | Input DI2 configuration (see lo11)   | 0   | 0    | 13   |       | R/W | HR 4012 |
| S | lo14 | Input DI2 logic (see lo12)   | 1   | 0    | 1    |       | R/W | CS 4013 |
| S | lo15 | Probe 3 type<br>0=NTC<br>1=NTC HT<br>2=0 to 5 Vdc ratiometric<br>3=0-20 mA<br>4=4-20 mA  | 0   | 0    | 4    |       | R/W | HR 4014 |
| S | lo16 | Minimum value of probe 3 (current or voltage)  | 0   | -199 | lo17 |       | R/W | HR 4015 |
| S | lo17 | Maximum value of probe 3 (current or voltage)  | 100 | lo16 | 999  |       | R/W | HR 4016 |
| S | lo18 | Probe 3 calibration  | 0   | -179 | 179  | Delta | R/W | HR 4017 |
| S | lo19 | Probe 3 noise filter (see lo05)  | 5   | 0    | 9    |       | R/W | HR 4018 |
| S | lo20 | Output NO1 relay logic<br>0=NO<br>1=NC   | 0   | 0    | 1    |       | R/W | CS 4019 |
| S | lo21 | Output NO2 relay logic (see lo20)  | 0   | 0    | 1    |       | R/W | CS 4020 |
| S | lo22 | Output NO3 relay logic (see lo20)  | 0   | 0    | 1    |       | R/W | CS 4021 |
| S | lo23 | Output NO4 relay logic (see lo20)  | 0   | 0    | 1    |       | R/W | CS 4022 |
| S | lo24 | Output NO5 alarm relay logic (see lo20)  | 0   | 0    | 1    |       | R/W | CS 4023 |
| S | lo25 | Output Y1 cut-off<br>0=Operation with cut-off<br>1=Operation at minimum speed  | 1   | 0    | 1    |       | R/W | CS 4024 |
| S | lo26 | Minimum value of analogue output Y1  | 0   | 0    | 100  | %     | R/W | HR 4025 |
| S | lo27 | Maximum value of analogue output Y1  | 100 | 0    | 100  | %     | R/W | HR 4026 |
| S | lo28 | Output Y2 cut-off (see lo25)   | 1   | 0    | 1    |       | R/W | CS 4027 |
| S | lo29 | Minimum value of analogue output Y2  | 0   | 0    | 100  | %     | R/W | HR 4028 |
| S | lo30 | Maximum value of analogue output Y2  | 100 | 0    | 100  | %     | R/W | HR 4029 |
| S | doF0 | Enable override digital outputs<br>0=DISABLE<br>1=ENABLE   | 0   | 0    | 1    |       | R/W | CS 4030 |
| S | doF1 | Override digital output 1  | 0   | 0    | 1    |       | R/W | CS 4031 |
| S | doF2 | Override digital output 2  | 0   | 0    | 1    |       | R/W | CS 4032 |
| S | doF3 | Override digital output 3  | 0   | 0    | 1    |       | R/W | CS 4033 |
| S | doF4 | Override digital output 4  | 0   | 0    | 1    |       | R/W | CS 4034 |
| S | doF5 | Override digital output 5  | 0   | 0    | 1    |       | R/W | CS 4035 |
| S | AoF0 | Enable override analogue outputs<br>(see doF0)   | 0   | 0    | 1    |       | R/W | CS 4036 |
| S | AoF1 | Override analogue output 1   | 0   | 0    | 1    |       | R/W | HR 4037 |
| S | AoF2 | Override analogue output 2   | 0   | 0    | 1    |       | R/W | HR 4038 |

## 6.4 Control configuration

| User | Code | Description   | Def.  | Min. | Max. | UOM | R/W | Modbus  |
|------|------|---|-------|------|------|-----|-----|---------|
| M    | B000 | Operating mode<br>0=Special operation (custom)<br>1=Direct<br>2=Reverse<br>3=Neutral zone<br>4=Reserved<br>5=Reserved<br>6=Direct/reverse changeover from DI1<br>7=Direct: set point and differential from DI1<br>8=Reverse: set point and differential from DI1<br>9=Direct/reverse with two separate set points<br>10=3 position valve  | 1     | 0    | 10   |     | R/W | HR 5000 |
| S    | B001 | Set point 1 differential  | 2     | 0.1  | 99.9 |     | R/W | HR 0005 |
| S    | B002 | Set point 2 differential  | 2     | 0.1  | 99.9 |     | R/W | HR 0006 |
| S    | B003 | Neutral zone differential   | 2     | 0    | 99.9 |     | R/W | HR 0007 |
| S    | B004 | Control type<br>0=Proportional<br>1=PID   | 0     | 0    | 1    |     | R/W | CS 5004 |
| S    | B005 | Enable anti-bump for PID<br>0=Disable<br>1=Enable   | 0     | 0    | 1    |     | R/W | CS 5005 |
| M    | B006 | Delay between activation of two different outputs   | 5     | 0    | 255  | Sec | R/W | HR 5006 |
| M    | B007 | Minimum time between two on cycles of the same output   | 0     | 0    | 900  | Sec | R/W | HR 5007 |
| M    | B008 | Delay between activation of two different outputs   | 5     | 0    | 255  | Sec | R/W | HR 5008 |
| M    | B009 | Minimum output off time   | 0     | 0    | 900  | Sec | R/W | HR 5009 |
| M    | B010 | Minimum output on time  | 0     | 0    | 900  | Sec | R/W | HR 5010 |
| M    | B011 | Output rotation (if B000=0, 1, 2, 7 or 8)<br>0=Rotation not active<br>1=Standard rotation   | 0     | 1    | 0    |     | R/W | HR 5011 |
| M    | B012 | Probe 2 operating mode (if B000=1, 2, 3, 10)<br>0=Not used<br>1=Differential operation (Prb1-Prb2)<br>2=Reserved<br>3=Reserved<br>4=Reserved<br>5=Enable regulation based on absolute set point<br>6=Enable regulation based on set point differential<br>7=Independent operation (circ.1 + circ.2)<br>8=Control on higher probe value<br>9=Control on lower probe value<br>10=Control set point from probe 2<br>11=Automatic summer/winter changeover from probe 2 | 0     | 0    | 11   |     | R/W | HR 5012 |
| S    | B013 | Minimum value of set point St1  | -50.0 | -199 | B014 |     | R/W | HR 5013 |
| S    | B014 | Maximum value of set point St1  | 60    | B013 | 800  |     | R/W | HR 5014 |
| S    | B015 | Minimum value of set point St2  | -50   | -199 | B016 |     | R/W | HR 5015 |
| S    | B016 | Maximum value of set point St2  | 60.0  | B015 | 800  |     | R/W | HR 5016 |

|   |      |   |     |       |       |     |     |         |
|---|------|---|-----|-------|-------|-----|-----|---------|
| S | B020 | Display<br>0=Probe 1<br>1=Probe 2<br>2=Digital input 1<br>3=Digital input 2<br>4=Set point 1<br>5=Set point 2<br>6=Probe 1/Probe 2 alternating<br>7=Output NO1 status<br>8=Output NO2 status<br>9=Output NO3 status<br>10=Output NO4 status<br>11=Output Y1 percentage<br>12=Output Y2 percentage<br>13=Probe 3<br>14=Control probe | 14  | 0     | 14    |     | R/W | HR 5017 |
| S | B021 | Logical differential on absolute set point/differential or season changeover from probe 2   | 1.5 | 0     | 99.9  |     | R/W | HR 5018 |
| S | B022 | Start threshold on absolute set point/differential or season changeover from probe 2  | -50 | -199  | 999.9 |     | R/W | HR 5019 |
| S | B023 | End threshold on absolute set point/differential or season changeover from probe 2  | 150 | -199  | 999.9 |     | R/W | HR 5020 |
| S | B024 | Summer compensation start value   | 35  | -99.9 | 999.9 |     | R/W | HR 5021 |
| S | B025 | Summer compensation end value   | 45  | -99.9 | 999.9 |     | R/W | HR 5022 |
| S | B026 | Maximum summer compensation value   | 5   | -99.9 | 999.9 |     | R/W | HR 5023 |
| S | B027 | Winter compensation start value   | 15  | -99.9 | 999.9 |     | R/W | HR 5024 |
| S | B028 | Winter compensation end value   | 0   | -99.9 | 999.9 |     | R/W | HR 5025 |
| S | B029 | Maximum winter compensation value   | 5   | -99.9 | 999.9 |     | R/W | HR 5026 |
| S | B030 | Summer compensation start value (economy)   | 35  | -99.9 | 999.9 |     | R/W | HR 5027 |
| S | B031 | Summer compensation end value (economy)   | 45  | -99.9 | 999.9 |     | R/W | HR 5028 |
| S | B032 | Maximum summer compensation value (economy)   | 5   | -99.9 | 999.9 |     | R/W | HR 5029 |
| S | B033 | Winter compensation start value (economy)   | 15  | -99.9 | 999.9 |     | R/W | HR 5030 |
| S | B034 | Winter compensation end value (economy)   | 0   | -99.9 | 999.9 |     | R/W | HR 5031 |
| S | B035 | Maximum winter compensation value (economy)   | 5   | -99.9 | 999.9 |     | R/W | HR 5032 |
| M | B036 | Probe 3 function<br>0=Disabled<br>1=Summer compensation<br>2=Winter compensation<br>3=Summer/winter compensation<br>4=Read only   | 0   | 0     | 4     |     | R/W | HR 5033 |
| S | B070 | Start regulation delay.<br>Set 0 to disable.  | 0   | 0     | 255   | Sec | R/W | HR 5034 |
| S | B071 | Soft start time when starting regulation.<br>Set 0 to disable.  | 0   | 0     | 255   | Sec | R/W | HR 5035 |
| S | B072 | St1 during soft start   | 20  | B013  | B014  |     | R/W | HR 5036 |
| S | B073 | St2 during soft start   | 40  | B013  | B014  |     | R/W | HR 5037 |
| S | B100 | 3-position valve opening time 0-100%  | 60  | 0     | 999   | Sec | R/W | HR 5038 |
| S | B101 | Type of 3-position valve regulation request<br>0=Standard<br>1=Dynamic  | 1   | 0     | 1     |     | R/W | CS 5039 |
| S | B102 | Dynamic 3-position valve regulation request reaction time   | 10  | 0     | 999   | Sec | R/W | HR 5040 |
| S | B103 | Dynamic 3-position valve regulation request threshold percentage  | 10  | 0     | 100   | %   | R/W | HR 5041 |

#### 6.4.1 PID parameter table (B004=1)

| User | Code | Description  | Def. | Min. | Max. | UOM | R/W | Modbus  |
|------|------|--------------|------|------|------|-----|-----|---------|
| S    | Bb01 | Control Ti 1 | 600  | 0    | 999  | Sec | R/W | HR 5300 |
| S    | Bb02 | Control Td 1 | 0    | 0    | 999  | Sec | R/W | HR 5301 |

|   |      |              |     |   |     |     |     |         |
|---|------|--------------|-----|---|-----|-----|-----|---------|
| S | Bb03 | Control Ti 2 | 600 | 0 | 999 | Sec | R/W | HR 5302 |
| S | Bb04 | Control Td 2 | 0   | 0 | 999 | Sec | R/W | HR 5303 |

## 6.4.2 Special parameter table (B000=0)

| User | Code | Description   | Def. | Min. | Max. | UOM | R/W | Modbus  |
|------|------|---|------|------|------|-----|-----|---------|
| M    | Ba01 | Control type on output NO1<br>0=Not enabled;<br>1=Control on thresholds<br>2=Control on St1 and B001<br>3=Control on St2 and B002<br>4=Alarm status<br>5=Unit status ON/OFF<br>6=Control status ON/OFF  | 0    | 0    | 6    |     | R/W | HR 5500 |
| M    | Ba02 | NO1 regulation probe<br>0=Probe 1<br>1=Probe 2<br>2=Probe 1/probe 2 from DI1<br>3=Probe 1 - probe 2<br>4=Probe 2 - probe 1  | 0    | 0    | 4    |     | R/W | HR 5501 |
| S    | Ba03 | NO1 activation  | 22   | -199 | 999  |     | R/W | HR 5502 |
| S    | Ba04 | NO1 deactivation  | 20   | -199 | 999  |     | R/W | HR 5503 |
| M    | Ba05 | NO1 output mode<br>0=Direct<br>1=Reverse<br>2=Direct/reverse from summer/winter   | 0    | 0    | 2    |     | R/W | HR 5504 |
| M    | Ba06 | Alarm dependency for NO1 activation<br>0=Global alarm<br>1=Probe 1 / circuit 1 alarm<br>2=Probe 2 / circuit 2 alarm<br>3=Probe 3 alarm<br>4=Probe 1 high alarm<br>5=Probe 1 low alarm<br>6=Probe 2 high alarm<br>7=Probe 2 low alarm<br>8=Probe 3 high alarm<br>9=Probe 3 low alarm | 0    | 0    | 9    |     | R/W | HR 5505 |
| M    | Ba07 | NO1 regulation type<br>0=ON-OFF<br>1=3-position valve opening<br>2=3-position valve closing   | 1    | 0    | 1    |     | R/W | HR 5506 |
| M    | Ba08 | Control type on output NO2<br>0=Not enabled;<br>1=Control on thresholds<br>2=Control on St1 and B001<br>3=Control on St2 and B002<br>4=Alarm status<br>5=Unit status ON/OFF<br>6=Control status ON/OFF  | 0    | 0    | 6    |     | R/W | HR 5507 |
| M    | Ba09 | NO2 regulation probe<br>0=Probe 1<br>1=Probe 2<br>2=Probe 1/probe 2 from DI1<br>3=Probe 1 - probe 2<br>4=Probe 2 - probe 1  | 0    | 0    | 4    |     | R/W | HR 5508 |
| S    | Ba10 | NO2 activation  | 22   | -199 | 999  |     | R/W | HR 5509 |
| S    | Ba11 | NO2 deactivation  | 20   | -199 | 999  |     | R/W | HR 5510 |
| M    | Ba12 | NO2 output mode<br>0=Direct<br>1=Reverse<br>2=Direct/reverse from summer/winter   | 0    | 0    | 2    |     | R/W | HR 5511 |
| M    | Ba13 | Alarm dependency for NO2 activation<br>0=Global alarm<br>1=Probe 1 / circuit 1 alarm<br>2=Probe 2 / circuit 2 alarm<br>3=Probe 3 alarm<br>4=Probe 1 high alarm<br>5=Probe 1 low alarm<br>6=Probe 2 high alarm<br>7=Probe 2 low alarm<br>8=Probe 3 high alarm<br>9=Probe 3 low alarm | 0    | 0    | 9    |     | R/W | HR 5512 |

|   |      |   |    |      |     |  |     |         |
|---|------|---|----|------|-----|--|-----|---------|
| M | Ba14 | NO2 regulation type<br>0=ON-OFF<br>1=3-position valve opening<br>2=3-position valve closing   | 0  | 0    | 2   |  | R/W | HR 5513 |
| M | Ba15 | Control type on output NO3<br>0=Not enabled;<br>1=Control on thresholds<br>2=Control on St1 and B001<br>3=Control on St2 and B002<br>4=Alarm status<br>5=Unit status ON/OFF<br>6=Control status ON/OFF  | 0  | 0    | 6   |  | R/W | HR 5514 |
| M | Ba16 | NO3 regulation probe<br>0=Probe 1<br>1=Probe 2<br>2=Probe 1/probe 2 from DI1<br>3=Probe 1 - probe 2<br>4=Probe 2 - probe 1  | 0  | 0    | 4   |  | R/W | HR 5515 |
| S | Ba17 | NO3 activation  | 22 | -199 | 999 |  | R/W | HR 5516 |
| S | Ba18 | NO3 deactivation  | 20 | -199 | 999 |  | R/W | HR 5517 |
| M | Ba19 | NO3 output mode<br>0=Direct<br>1=Reverse<br>2=Direct/reverse from summer/winter   | 0  | 0    | 2   |  | R/W | HR 5518 |
| M | Ba20 | Alarm dependency for NO3 activation<br>0=Global alarm<br>1=Probe 1 / circuit 1 alarm<br>2=Probe 2 / circuit 2 alarm<br>3=Probe 3 alarm<br>4=Probe 1 high alarm<br>5=Probe 1 low alarm<br>6=Probe 2 high alarm<br>7=Probe 2 low alarm<br>8=Probe 3 high alarm<br>9=Probe 3 low alarm | 0  | 0    | 9   |  | R/W | HR 5519 |
| M | Ba21 | NO3 regulation type<br>0=ON-OFF<br>1=3-position valve opening<br>2=3-position valve closing   | 0  | 0    | 2   |  | R/W | HR 5520 |
| M | Ba22 | Control type on output NO4<br>0=Not enabled;<br>1=Control on thresholds<br>2=Control on St1 and B001<br>3=Control on St2 and B002<br>4=Alarm status<br>5=Unit status ON/OFF<br>6=Control status ON/OFF  | 0  | 0    | 6   |  | R/W | HR 5521 |
| M | Ba23 | NO4 regulation probe<br>0=Probe 1<br>1=Probe 2<br>2=Probe 1/probe 2 from DI1<br>3=Probe 1 - probe 2<br>4=Probe 2 - probe 1  | 0  | 0    | 4   |  | R/W | HR 5522 |
| S | Ba24 | NO4 activation  | 22 | -199 | 999 |  | R/W | HR 5523 |
| S | Ba25 | NO4 deactivation  | 20 | -199 | 999 |  | R/W | HR 5524 |
| M | Ba26 | NO4 output mode<br>0=Direct<br>1=Reverse<br>2=Direct/reverse from summer/winter   | 0  | 0    | 2   |  | R/W | HR 5525 |
| M | Ba27 | Alarm dependency for NO4 activation<br>0=Global alarm<br>1=Probe 1 / circuit 1 alarm<br>2=Probe 2 / circuit 2 alarm<br>3=Probe 3 alarm<br>4=Probe 1 high alarm<br>5=Probe 1 low alarm<br>6=Probe 2 high alarm<br>7=Probe 2 low alarm<br>8=Probe 3 high alarm<br>9=Probe 3 low alarm | 0  | 0    | 9   |  | R/W | HR 5526 |

|   |      |  |    |      |     |  |     |         |
|---|------|--|----|------|-----|--|-----|---------|
| M | Ba28 | NO4 regulation type<br>0=ON-OFF<br>1=3-position valve opening<br>2=3-position valve closing                                      | 0  | 0    | 2   |  | R/W | HR 5527 |
| M | Ba30 | Control type on output Y1<br>0=Not enabled;<br>1=Control on thresholds<br>2=Control on St1 and B001<br>3=Control on St2 and B002 | 0  | 0    | 6   |  | R/W | HR 5528 |
| M | Ba31 | Y1 regulation probe<br>0=Probe 1<br>1=Probe 2<br>2=Probe 1/probe 2 from DI1<br>3=Probe 1 - probe 2<br>4=Probe 2 - probe 1        | 0  | 0    | 4   |  | R/W | HR 5529 |
| S | Ba32 | Output Y1 at 100%  | 22 | -199 | 999 |  | R/W | HR 5530 |
| S | Ba33 | Output Y1 at 0%  | 20 | -199 | 999 |  | R/W | HR 5531 |
| M | Ba34 | Y1 output mode<br>0=Direct<br>1=Reverse<br>2=Direct/reverse from summer/winter   | 0  | 0    | 2   |  | R/W | HR 5532 |
| M | Ba40 | Control type on output Y2<br>0=Not enabled;<br>1=Control on thresholds<br>2=Control on St1 and B001<br>3=Control on St2 and B002 | 0  | 0    | 6   |  | R/W | HR 5533 |
| M | Ba41 | Y2 regulation probe<br>0=Probe 1<br>1=Probe 2<br>2=Probe 1/probe 2 from DI1<br>3=Probe 1 - probe 2<br>4=Probe 2 - probe 1        | 0  | 0    | 4   |  | R/W | HR 5534 |
| S | Ba42 | Output Y2 at 100%  | 22 | -199 | 999 |  | R/W | HR 5535 |
| S | Ba43 | Output Y2 at 0%  | 20 | -199 | 999 |  | R/W | HR 5536 |
| M | Ba44 | Y2 output mode<br>0=Direct<br>1=Reverse<br>2=Direct/reverse from summer/winter   | 0  | 0    | 2   |  | R/W | HR 5537 |

## 6.5 Alarm configuration

| User | Code | Description  | Def.  | Min. | Max. | UOM   | R/W | Modbus  |
|------|------|--|-------|------|------|-------|-----|---------|
| S    | C001 | Status of the regulation outputs on circuit 1 with probe 1 alarm<br>(See the table in paragraph 8.2) | 0     | 0    | 63   |       | R/W | HR 6000 |
| S    | C002 | Status of the regulation outputs on circuit 2 with probe 2 alarm<br>(See the table in paragraph 8.2) | 0     | 0    | 63   |       | R/W | HR 6001 |
| S    | C003 | Probe 1 low alarm threshold  | -50.0 | -199 | B014 |       | R/W | HR 0018 |
| S    | C004 | Probe 1 high alarm threshold   | 150   | C003 | 800  |       | R/W | HR 0019 |
| S    | C005 | Probe 1 alarm differential   | 2     | 0    | 99   | Delta | R/W | HR 0020 |
| S    | C006 | Probe 1 alarm delay and delayed alarms from DI1  | 60    | 0    | 250  | Sec   | R/W | HR 6005 |
| S    | C007 | Probe 1 alarm threshold type<br>0=relative<br>1=absolute   | 1     | 0    | 1    |       | R/W | CS 6006 |
| S    | C008 | Probe 2 low alarm threshold  | -50   | -199 | C009 |       | R/W | HR 0030 |
| S    | C009 | Probe 2 high alarm threshold   | 150   | C008 | 800  |       | R/W | HR 0031 |
| S    | C010 | Probe 2 alarm differential   | 2     | 0    | 99   | Delta | R/W | HR 0032 |
| S    | C011 | Probe 2 alarm delay and delayed alarms from DI2  | 60    | 0    | 999  | Sec   | R/W | HR 6010 |
| S    | C012 | Probe 2 alarm threshold type<br>(see C007)   | 1     | 0    | 1    |       | R/W | CS 6011 |
| S    | C020 | Status of regulation outputs with alarm from DI1<br>(See the table in paragraph 8.2)                 | 0     | 0    | 63   |       | R/W | HR 6012 |
| S    | C021 | Status of regulation outputs with alarm from DI2<br>(See the table in paragraph 8.2)                 | 0     | 0    | 63   |       | R/W | HR 6013 |
| S    | C030 | Probe 3 low alarm threshold  | -50.0 | -199 | B014 |       | R/W | HR 6014 |
| S    | C031 | Probe 3 high alarm threshold   | 150   | C030 | 800  |       | R/W | HR 6015 |
| S    | C032 | Probe 3 alarm differential   | 2     | 0    | 99   | Delta | R/W | HR 6016 |
| S    | C033 | Probe 3 alarm delay  | 60    | 0    | 999  | Sec   | R/W | HR 6017 |
| S    | ClrH | Clear the alarm log  | 0     | 0    | 1    |       | R/W | CS 1100 |

## 6.6 Settings

| User | Code | Description  | Def. | Min. | Max. | UOM | R/W | Modbus        |
|------|------|--|------|------|------|-----|-----|---------------|
| S    | Hd00 | BMS address  | 1    | 1    | 247  |     | R/W | Not available |
| S    | Hd01 | BMS baud rate<br>0=1200<br>1=2400<br>2=4800<br>3=9600<br>4=19200<br>5=38400<br>6=57600<br>7=115200<br>8=375000 | 4    | 0    | 8    |     | R/W | Not available |
| S    | Hd02 | BMS network settings<br>0= 8-NONE-1<br>1= 8-NONE-2<br>2= 8-EVEN-1<br>3= 8-EVEN-2<br>4= 8-ODD-1<br>5= 8-ODD-2   | 1    | 0    | 5    |     | R/W | Not available |
| S    | Hd03 | Apply changes to BMS port  | 0    | 0    | 1    |     | R/W | Not available |
| S    | Hd04 | Enable unit ON/OFF command via BMS network   | 0    | 0    | 1    |     | R/W | CS 7000       |
| S    | Hd05 | Delay at controller power on.<br>Set 0 to disable  | 0    | 0    | 255  | Sec | R/W | HR 7001       |
| M    | Hd97 | Reset unit and output hour counters  | 0    | 0    | 1    |     | R/W | CS 7002       |
| S    | Hd98 | Enable buzzer  | 0    | 0    | 1    |     | R/W | CS 7003       |
| S    | Hd99 | Main screen return delay   | 60   | 10   | 9999 | Sec | R/W | HR 7004       |
| M    | rStr | Restore default parameters   | 0    | 0    | 1    |     | R/W | Not available |

## 6.7 Clock

| User | Code | Description             | Def. | Min. | Max. | UOM | R/W | Modbus  |
|------|------|-------------------------|------|------|------|-----|-----|---------|
| U    | dAY  | Day setting             |      | 1    | 31   |     | R/W | HR 8006 |
| U    | Mont | Month setting           |      | 1    | 12   |     | R/W | HR 8007 |
| U    | YEAr | Year setting            |      | 17   | 99   |     | R/W | HR 8008 |
| U    | Hour | Hour setting            |      | 0    | 23   |     | R/W | HR 8009 |
| U    | Min  | Minutes setting         |      | 0    | 59   |     | R/W | HR 8010 |
| S    | SetC | Apply date-time changes |      | 0    | 1    |     | R/W | CS 8011 |

## 6.8 Scheduler

| User | Code | Description   | Def. | Min. | Max. | UOM | R/W | Modbus  |
|------|------|---|------|------|------|-----|-----|---------|
| U    | Hb00 | Enable scheduler  | 0    | 0    | 1    |     | R/W | CS 9000 |
| U    | Hb01 | P1 Time band 1 – Enable                                     | 1    | 0    | 1    |     | R/W | CS 9001 |
| U    | Hb02 | P1 Time band 1 – Start hours                                | 8    | 0    | 23   |     | R/W | HR 9002 |
| U    | Hb03 | P1 Time band 1 – Start minutes                              | 0    | 0    | 59   |     | R/W | HR 9003 |
| U    | Hb04 | P1 Time band 1 – Profile<br>0=COMFORT<br>1=ECONOMY<br>2=OFF | 0    | 0    | 2    |     | R/W | HR 9004 |
| U    | Hb05 | P1 Time band 2 - Enable                                     | 1    | 0    | 1    |     | R/W | CS 9005 |
| U    | Hb06 | P1 Time band 2 – Start hours                                | 22   | 0    | 23   |     | R/W | HR 9006 |
| U    | Hb07 | P1 Time band 2 – Start minutes                              | 0    | 0    | 59   |     | R/W | HR 9007 |
| U    | Hb08 | P1 Time band 2 – Profile (see Hb04)                         | 1    | 0    | 2    |     | R/W | HR 9008 |
| U    | Hb09 | P1 Time band 3 – Enable                                     | 0    | 0    | 1    |     | R/W | CS 9009 |
| U    | Hb10 | P1 Time band 3 – Start hours                                | 0    | 0    | 23   |     | R/W | HR 9010 |
| U    | Hb11 | P1 Time band 3 – Start minutes                              | 0    | 0    | 59   |     | R/W | HR 9011 |
| U    | Hb12 | P1 Time band 3 – Profile (see Hb04)                         | 0    | 0    | 2    |     | R/W | HR 9012 |
| U    | Hb13 | P1 Time band 4 – Enable                                     | 0    | 0    | 1    |     | R/W | CS 9013 |
| U    | Hb14 | P1 Time band 4 – Start hours                                | 0    | 0    | 23   |     | R/W | HR 9014 |
| U    | Hb15 | P1 Time band 4 – Start minutes                              | 0    | 0    | 59   |     | R/W | HR 9015 |
| U    | Hb16 | P1 Time band 4 – Profile (see Hb04)                         | 0    | 0    | 2    |     | R/W | HR 9016 |
| U    | Hb17 | P2 Time band 1 – Enable                                     | 1    | 0    | 1    |     | R/W | CS 9017 |
| U    | Hb18 | P2 Time band 1 – Start hours                                | 8    | 0    | 23   |     | R/W | HR 9018 |
| U    | Hb19 | P2 Time band 1 – Start minutes                              | 0    | 0    | 59   |     | R/W | HR 9019 |
| U    | Hb20 | P2 Time band 1 – Profile (see Hb04)                         | 0    | 0    | 2    |     | R/W | HR 9020 |
| U    | Hb21 | P2 Time band 2 – Enable                                     | 1    | 0    | 1    |     | R/W | CS 9021 |
| U    | Hb22 | P2 Time band 2 – Start hours                                | 22   | 0    | 23   |     | R/W | HR 9022 |
| U    | Hb23 | P2 Time band 2 – Start minutes                              | 0    | 0    | 59   |     | R/W | HR 9023 |
| U    | Hb24 | P2 Time band 2 - Profile (see Hb04)                         | 2    | 0    | 2    |     | R/W | HR 9024 |
| U    | Hb25 | P2 Time band 3 – Enable                                     | 0    | 0    | 1    |     | R/W | CS 9025 |
| U    | Hb26 | P2 Time band 3 – Start hours                                | 0    | 0    | 23   |     | R/W | HR 9026 |
| U    | Hb27 | P2 Time band 3 – Start minutes                              | 0    | 0    | 59   |     | R/W | HR 9027 |
| U    | Hb28 | P2 Time band 3 – Profile (see Hb04)                         | 0    | 0    | 2    |     | R/W | HR 9028 |
| U    | Hb29 | P2 Time band 4 – Enable                                     | 0    | 0    | 1    |     | R/W | CS 9029 |
| U    | Hb30 | P2 Time band 4 – Start hours                                | 0    | 0    | 23   |     | R/W | HR 9030 |
| U    | Hb31 | P2 Time band 4 – Start minutes                              | 0    | 0    | 59   |     | R/W | HR 9031 |
| U    | Hb32 | P2 Time band 4 – profile (see Hb04)                         | 0    | 0    | 2    |     | R/W | HR 9032 |
| U    | Hb33 | P3 Time band 1 – Enable                                     | 1    | 0    | 1    |     | R/W | CS 9033 |
| U    | Hb34 | P3 Time band 1 – Start hours                                | 8    | 0    | 23   |     | R/W | HR 9034 |
| U    | Hb35 | P3 Time band 1 – Start minutes                              | 0    | 0    | 59   |     | R/W | HR 9035 |
| U    | Hb36 | P3 Time band 1 – Profile (see Hb04)                         | 1    | 0    | 2    |     | R/W | HR 9036 |
| U    | Hb37 | P3 Time band 2 – Enable                                     | 1    | 0    | 1    |     | R/W | CS 9037 |
| U    | Hb38 | P3 Time band 2 – Start hours                                | 22   | 0    | 23   |     | R/W | HR 9038 |
| U    | Hb39 | P3 Time band 2 – Start minutes                              | 0    | 0    | 59   |     | R/W | HR 9039 |
| U    | Hb40 | P3 Time band 2 – Profile (see Hb04)                         | 2    | 0    | 2    |     | R/W | HR 9040 |
| U    | Hb41 | P3 Time band 3 – Enable                                     | 0    | 0    | 1    |     | R/W | CS 9041 |
| U    | Hb42 | P3 Time band 3 – Start hours                                | 0    | 0    | 23   |     | R/W | HR 9042 |
| U    | Hb43 | P3 Time band 3 – Start minutes                              | 0    | 0    | 59   |     | R/W | HR 9043 |
| U    | Hb44 | P3 Time band 3 – Profile (see Hb04)                         | 0    | 0    | 2    |     | R/W | HR 9044 |
| U    | Hb45 | P3 Time band 4 – Enable                                     | 0    | 0    | 1    |     | R/W | CS 9045 |
| U    | Hb46 | P3 Time band 4 – Start hours                                | 0    | 0    | 23   |     | R/W | HR 9046 |
| U    | Hb47 | P3 Time band 4 – Start minutes                              | 0    | 0    | 59   |     | R/W | HR 9047 |

|   |      |   |   |   |    |  |     |         |
|---|------|---|---|---|----|--|-----|---------|
| U | Hb48 | P3 Time band 4 – Profile (see Hb04)   | 0 | 0 | 2  |  | R/W | HR 9048 |
| U | Hb49 | Monday profile<br>0=COMFORT<br>1=ECONOMY<br>2=OFF<br>3=Program 1 (P1)<br>4=Program 2 (P2)<br>5=Program 3 (P3) | 3 | 0 | 5  |  | R/W | HR 9049 |
| U | Hb50 | Tuesday profile (see Hb49)  | 3 | 0 | 5  |  | R/W | HR 9050 |
| U | Hb51 | Wednesday profile (see Hb49)  | 3 | 0 | 5  |  | R/W | HR 9051 |
| U | Hb52 | Thursday profile (see Hb49)   | 3 | 0 | 5  |  | R/W | HR 9052 |
| U | Hb53 | Friday profile (see Hb49)   | 4 | 0 | 5  |  | R/W | HR 9053 |
| U | Hb54 | Saturday profile (see Hb49)   | 5 | 0 | 5  |  | R/W | HR 9054 |
| U | Hb55 | Sunday profile (see Hb49)   | 5 | 0 | 5  |  | R/W | HR 9055 |
| U | Hb56 | Enable vacation period  | 0 | 0 | 1  |  | R/W | CS 9056 |
| U | Hb57 | Vacation start day  | 1 | 1 | 31 |  | R/W | HR 9057 |
| U | Hb58 | Vacation start month  | 1 | 1 | 12 |  | R/W | HR 9058 |
| U | Hb59 | Vacation end day  | 1 | 1 | 31 |  | R/W | HR 9059 |
| U | Hb60 | Vacation end month  | 1 | 1 | 12 |  | R/W | HR 9060 |
| U | Hb61 | Vacation period mode (see Hb49)   | 0 | 0 | 5  |  | R/W | HR 9061 |

# 7. SUPERVISION

The Universal Controller provides, via the J4-BMS terminal, a database of registers available for supervision via the Modbus RTU protocol over RS485. The BMS port is set by default with the following communication parameters, which can be set on the user interface and in Applica:

| Code | Description               | Default  |
|------|---------------------------|----------|
| Hd00 | BMS address               | 1        |
|      | BMS baud rate             | 19200    |
|      | 0=1200                    | kbps     |
|      | 1=2400                    |          |
|      | 2=4800                    |          |
|      | 3=9600                    |          |
| Hd01 | 4=19200                   |          |
|      | 5=38400                   |          |
|      | 6=57600                   |          |
|      | 7=115200                  |          |
|      | 8=375000                  |          |
|      | BMS network settings      | 8-NONE-2 |
|      | 0= 8-NONE-1               |          |
|      | 1= 8-NONE-2               |          |
| Hd02 | 2= 8-EVEN-1               |          |
|      | 3= 8-EVEN-2               |          |
|      | 4= 8-ODD-1                |          |
|      | 5= 8-ODD-2                |          |
| Hd03 | Apply changes to BMS port | 0        |

ⓘ Notice:

- fixed 8 bit data bits.
- To make the changes to parameters Hd00, Hd01 and Hd02 active, parameter Hd03 must be set to 1 (Yes).
- The Modbus registers of the regulation variables and parameters are available in an extended list downloadable from [ksa.carel.com](http://ksa.carel.com).

## 7.1 Unit on/off management from BMS

The unit On/Off status can also be managed from the BMS supervisor.

By setting "Enable unit ON/OFF command via BMS network" (parameter Hd04, Coil Status register 7000) and "Set unit On/Off from keypad" (parameter UnSt, Coil Status register 35), unit ON/OFF can be controller via BMS using variable BmsOffOn (Coil Status register 1000).

## 7.2 Supervisor model for Boss and PlantVisorPRO range

The supervisor model in .xml format for the Boss and PlantVisorPRO range supervisors is available on [ksa.carel.com](http://ksa.carel.com), in the reserved area for the Universal Controller.

# 8. ALARMS AND SIGNALS

## 8.1 Types of alarms

The controller manages two types of alarms, depending on the reset mode:

- Automatic: the alarm is reset automatically when the alarm condition ceases
- Manual: the needs to reset the alarm manually (by pressing and holding the ALARM button or by sending a specific command from Applica or the supervisor) to resume regulation. For some alarms, the reset mode can be configured by parameter.

Each alarm situation identified is signalled on the display by the flashing red ALARM icon (see paragraph 3.2.2).

## 8.2 Override regulation outputs

The probe 1, probe 2 alarms and the alarms from DI1 and DI2 (see the complete alarm list in paragraph 8.3) can be used to override the regulation outputs when the alarm is activated. This only happens if the unit is initially On from all available and configured sources (keypad, digital input, time bands and supervisor).

The following parameters are used to set these constraints:

| Code | Description  | Default |
|------|--|---------|
| C001 | Status of the regulation outputs on circuit 1 with probe 1 alarm | 0       |
| C002 | Status of the regulation outputs on circuit 2 with probe 2 alarm | 0       |
| C020 | Status of regulation outputs with alarm from DI1                 | 0       |
| C021 | Status of regulation outputs with alarm from DI2                 | 0       |

Each value from 0 to 63 can set different overrides on the digital and analogue outputs, as shown in the following summary table:

| C001 – C002 – C020 – C021 |     |     |     |     |     |     |     |     |     |     |     |     |     |     |     |
|---------------------------|-----|-----|-----|-----|-----|-----|-----|-----|-----|-----|-----|-----|-----|-----|-----|
| 0                         | 1   | 2   | 3   | 4   | 5   | 6   | 7   | 8   | 9   | 10  | 11  | 12  | 13  | 14  | 15  |
| NO1                       | NO1 | NO1 | NO1 | NO1 | NO1 | NO1 | NO1 | NO1 | NO1 | NO1 | NO1 | NO1 | NO1 | NO1 | NO1 |
| NO2                       | NO2 | NO2 | NO2 | NO2 | NO2 | NO2 | NO2 | NO2 | NO2 | NO2 | NO2 | NO2 | NO2 | NO2 | NO2 |
| NO3                       | NO3 | NO3 | NO3 | NO3 | NO3 | NO3 | NO3 | NO3 | NO3 | NO3 | NO3 | NO3 | NO3 | NO3 | NO3 |
| NO4                       | NO4 | NO4 | NO4 | NO4 | NO4 | NO4 | NO4 | NO4 | NO4 | NO4 | NO4 | NO4 | NO4 | NO4 | NO4 |
| Y1                        | Y1  | Y1  | Y1  | Y1  | Y1  | Y1  | Y1  | Y1  | Y1  | Y1  | Y1  | Y1  | Y1  | Y1  | Y1  |
| Y2                        | Y2  | Y2  | Y2  | Y2  | Y2  | Y2  | Y2  | Y2  | Y2  | Y2  | Y2  | Y2  | Y2  | Y2  | Y2  |
| 16                        | 17  | 18  | 19  | 20  | 21  | 22  | 23  | 24  | 25  | 26  | 27  | 28  | 29  | 30  | 31  |
| NO1                       | NO1 | NO1 | NO1 | NO1 | NO1 | NO1 | NO1 | NO1 | NO1 | NO1 | NO1 | NO1 | NO1 | NO1 | NO1 |
| NO2                       | NO2 | NO2 | NO2 | NO2 | NO2 | NO2 | NO2 | NO2 | NO2 | NO2 | NO2 | NO2 | NO2 | NO2 | NO2 |
| NO3                       | NO3 | NO3 | NO3 | NO3 | NO3 | NO3 | NO3 | NO3 | NO3 | NO3 | NO3 | NO3 | NO3 | NO3 | NO3 |
| NO4                       | NO4 | NO4 | NO4 | NO4 | NO4 | NO4 | NO4 | NO4 | NO4 | NO4 | NO4 | NO4 | NO4 | NO4 | NO4 |
| Y1                        | Y1  | Y1  | Y1  | Y1  | Y1  | Y1  | Y1  | Y1  | Y1  | Y1  | Y1  | Y1  | Y1  | Y1  | Y1  |
| Y2                        | Y2  | Y2  | Y2  | Y2  | Y2  | Y2  | Y2  | Y2  | Y2  | Y2  | Y2  | Y2  | Y2  | Y2  | Y2  |
| 32                        | 33  | 34  | 35  | 36  | 37  | 38  | 39  | 40  | 41  | 42  | 43  | 44  | 45  | 46  | 47  |
| NO1                       | NO1 | NO1 | NO1 | NO1 | NO1 | NO1 | NO1 | NO1 | NO1 | NO1 | NO1 | NO1 | NO1 | NO1 | NO1 |
| NO2                       | NO2 | NO2 | NO2 | NO2 | NO2 | NO2 | NO2 | NO2 | NO2 | NO2 | NO2 | NO2 | NO2 | NO2 | NO2 |
| NO3                       | NO3 | NO3 | NO3 | NO3 | NO3 | NO3 | NO3 | NO3 | NO3 | NO3 | NO3 | NO3 | NO3 | NO3 | NO3 |
| NO4                       | NO4 | NO4 | NO4 | NO4 | NO4 | NO4 | NO4 | NO4 | NO4 | NO4 | NO4 | NO4 | NO4 | NO4 | NO4 |
| Y1                        | Y1  | Y1  | Y1  | Y1  | Y1  | Y1  | Y1  | Y1  | Y1  | Y1  | Y1  | Y1  | Y1  | Y1  | Y1  |
| Y2                        | Y2  | Y2  | Y2  | Y2  | Y2  | Y2  | Y2  | Y2  | Y2  | Y2  | Y2  | Y2  | Y2  | Y2  | Y2  |
| 48                        | 49  | 50  | 51  | 52  | 53  | 54  | 55  | 56  | 57  | 58  | 59  | 60  | 61  | 62  | 63  |
| NO1                       | NO1 | NO1 | NO1 | NO1 | NO1 | NO1 | NO1 | NO1 | NO1 | NO1 | NO1 | NO1 | NO1 | NO1 | NO1 |
| NO2                       | NO2 | NO2 | NO2 | NO2 | NO2 | NO2 | NO2 | NO2 | NO2 | NO2 | NO2 | NO2 | NO2 | NO2 | NO2 |
| NO3                       | NO3 | NO3 | NO3 | NO3 | NO3 | NO3 | NO3 | NO3 | NO3 | NO3 | NO3 | NO3 | NO3 | NO3 | NO3 |
| NO4                       | NO4 | NO4 | NO4 | NO4 | NO4 | NO4 | NO4 | NO4 | NO4 | NO4 | NO4 | NO4 | NO4 | NO4 | NO4 |
| Y1                        | Y1  | Y1  | Y1  | Y1  | Y1  | Y1  | Y1  | Y1  | Y1  | Y1  | Y1  | Y1  | Y1  | Y1  | Y1  |
| Y2                        | Y2  | Y2  | Y2  | Y2  | Y2  | Y2  | Y2  | Y2  | Y2  | Y2  | Y2  | Y2  | Y2  | Y2  | Y2  |

**Key**

GREEN = digital output active / analogue output at 100%  
 GREY = digital output off / analogue output at 0%

Example:

to activate outputs NO1, NO3, Y1 and deactivate NO2, NO4, Y2 following a serious alarm from digital input DI1, to set parameter C020 to 21.

## 8.3 Alarm list

ⓘ Notice:

Automatic reset: the alarm is reset automatically when the alarm condition ceases

Manual reset: the user needs to reset the alarm and restart regulation

Modbus: HR=Holding register; IR=Analogue input; CS=Coil status; DI=Digital input; (2R)=32 bit register;

| Code | Cause  | Reset                     | Action  | Solution   | Modbus  |
|------|--|---------------------------|---|--|---------|
| A01  | Probe 1 (S06) disconnected alarm                                       | Automatic                 | Stop regulation on circuit 1 and override corresponding outputs according to C001   | Check the connection of probe 1 (S06)  | DI 0008 |
| A02  | Probe 2 (S04) disconnected alarm                                       | Automatic                 | If B000 > 0 and B012 = 1 or 2 or B000 = 0, circuit 2 regulation is stopped and the corresponding outputs are overridden according to C002. Otherwise, regulation is not stopped | Check the connection of probe 2 (S04)  | DI 0020 |
| A03  | Probe 3 (S05) disconnected alarm                                       | Automatic                 | Stop compensation   | Check the connection of probe 3 (S05)  | DI 0009 |
| A04  | The value of probe 1 is higher than the threshold C004 for a time C006 | Automatic                 | Signal only   | Check the setting of parameters C004, C005, C006, C007.                      | DI 0011 |
| A05  | The value of probe 1 is lower than the threshold C003 for a time C006  | Automatic                 | Signal only   | Check the setting of parameters C003, C005, C006, C007.                      | DI 0012 |
| A06  | The value of probe 2 is higher than the threshold C009 for a time C011 | Automatic                 | Signal only   | Check the setting of parameters C009, C010, C011, C012.                      | DI 0021 |
| A07  | The value of probe 2 is lower than the threshold C008 for a time C011  | Automatic                 | Signal only   | Check the setting of parameters C008, C010, C011, C012.                      | DI 0022 |
| A08  | The value of probe 3 is higher than the threshold C031 for a time C033 | Automatic                 | Signal only   | Check the setting of parameters C031, C032, C033.                            | DI 0048 |
| A09  | The value of probe 3 is lower than the threshold C030 for a time C033  | Automatic                 | Signal only   | Check the setting of parameters C030, C032, C033.                            | DI 0049 |
| A10  | Immediate/delayed signal-only alarm from digital input                 | Automatic                 | Signal only   | Check the cause of the digital input alarm signal.                           | DI 0051 |
| A11  | Immediate/delayed serious alarm from digital input on circuit 1        | According to I011 or I013 | Stop circuit 1 regulation and override corresponding output according to C020 (if assigned to DI1) or C021 (if assigned to DI2)   | Check the cause of the digital input alarm signal.                           | DI 0010 |
| A12  | Immediate/delayed serious alarm from digital input on circuit 2        | According to I011 or I013 | Stop circuit 2 regulation and override corresponding output according to C020 (if assigned to DI1) or C021 (if assigned to DI2)   | Check the cause of the digital input alarm signal.                           | DI 0052 |
| A98  | Error in number of permanent memory writes                             | Manual                    | Signal only   | Try manually resetting the alarm.<br>If the alarm persists, contact service. | DI 0016 |
| A99  | RTC error  | Automatic                 | Signal only   | Update the time via display or Applica.                                      | DI 0015 |

# 9. TECHNICAL SPECIFICATIONS

| Model                          | U20R00UC00200 (Panel model)                                 | U20R00UC00250 (DIN rail model) |
|--------------------------------|---|--------------------------------|
| <b>Physical specifications</b> |   |                                |
| Dimensions                     | See figures   | See figures                    |
| Case                           | Polycarbonate   | Polycarbonate                  |
| Mounting                       | Panel   | DIN rail                       |
| Ball pressure test temperature | 125°C   | 125°C                          |
| Ingress protection             | IP20 (rear) - IP65 (front)                                  | IP00                           |
| Front cleaning                 | Use soft, non-abrasive cloth and neutral detergent or water | -                              |

| <b>Environmental conditions</b> |                                  |                                  |
|---------------------------------|----------------------------------|----------------------------------|
| Storage conditions              | -40T85°C, <90% RH non-condensing | -40T85°C, <90% RH non-condensing |
| Operating conditions            | -20T60°C, <90% RH non-condensing | -20T60°C, <90% RH non-condensing |

| <b>Electrical specifications</b>           |  |  |
|--|--|--|
| Rated power supply                         | 24 Vac/dc<br>(SELV or PELV power supply, Class 2)            | 24 Vac/dc<br>(SELV or PELV power supply, Class 2)            |
| Operating power supply voltage             | 24 Vac/dc; +10%-15%  | 24 Vac/dc; +10%-15%  |
| Input frequency (AC)                       | 50/60 Hz   | 50/60 Hz   |
| Maximum current draw                       | 600 mA rms   | 600 mA rms   |
| Power for transformer sizing               | 15VA   | 15VA   |
| Clock                                      | Precision: ±50 ppm; min. retention time after power off: 72h | Precision: ±50 ppm; min. retention time after power off: 72h |
| Software class and structure               | A  | A  |
| Pollution degree                           | 3  | 3  |
| Class of protection against electric shock | To be incorporated in class I or II appliances               | To be incorporated in class I or II appliances               |
| Type of action and disconnection           | See table in paragraph 1.3.1                                 | See table in paragraph 1.3.1                                 |
| Rated impulse voltage                      | Relay outputs: 4 kV; 24 V input: 0.5 kV                      | Relay outputs: 4 kV; 24 V input: 0.5 kV                      |
| Surge immunity category                    | Relay outputs: III; 24 V input: II                           | Relay outputs: III; 24 V input: II                           |
| Control device construction                | Device to be incorporated                                    | Device to be incorporated                                    |
| Terminal block                             | Plug-in male-female.<br>Wire sizes: see the connector table  | Plug-in male-female.<br>Wire sizes: see the connector table  |
| Purpose of the controller                  | Electrical operating regulation                              | Electrical operating regulation                              |

| <b>User interface</b> |   |   |
|-----------------------|---|---|
| Buzzer                | Integrated  | Integrated  |
| Display               | LED 2 rows, decimal point, and multi-function icons | LED 2 rows, decimal point, and multi-function icons |

| <b>Connectivity</b>       |  |  |
|---------------------------|--|--|
| Bluetooth Low Energy      | Max distance 10m, variable according to the mobile device used | Max distance 10m, variable according to the mobile device used |
| BMS serial interface      | Modbus over RS485, not opto-isolated                           | Modbus over RS485, not opto-isolated                           |
| FieldBUS serial interface | Modbus over RS485, not opto-isolated                           | Modbus over RS485, not opto-isolated                           |

| <b>Analogue inputs (Lmax=10)</b>   |   |   |
|--|---|---|
| J2 S1, S2, S3: NTC<br>S5: 0 to 5 V ratiometric / 4-20 mA / NTC                                   | NTC: resolution 0.1°C; 10Kohm@25°C, error: ±1°C in range -50T50°C, ±3°C in the range 50T90°C<br>0-5 V ratiometric: error 2% fs, typical 1%;<br>4-20 mA: error 2% fs, typical 1% | NTC: resolution 0.1°C; 10Kohm@25°C, error: ±1°C in range -50T50°C, ±3°C in the range 50T90°C<br>0-5 V ratiometric: error 2% fs, typical 1%;<br>4-20 mA: error 2% fs, typical 1% |
| J3 S4: 0 to 5 V ratiometric / 4-20 mA / NTC<br>S6: 0 to 5 V ratiometric / 0-10 V / 4-20 mA / NTC | 0-5 V ratiometric: error 2% fs, typical 1%;<br>4-20 mA: error 2% fs, typical 1%<br>0-10 V: error 2% fs, typical 1%  | 0-5 V ratiometric: error 2% fs, typical 1%;<br>4-20 mA: error 2% fs, typical 1%<br>0-10 V: error 2% fs, typical 1%  |
| J9 S7: NTC (DIN version only)  | -   | NTC: resolution 0.1 °C; 10Kohm@25°C, error: ± 1°C in the range - 50T50°C ± 3°C in the range 50T90°C   |

| <b>Digital inputs (Lmax=10)</b> |   |   |
|---------------------------------|---|---|
| J2 ID1, ID2                     | Voltage-free contact, not opto-isolated, typical closing current 6 mA, open contact voltage 13 V, open contact resistance 13 V, max contact resistance 50 Ω. (*) Fast digital input: 0-2 kHz; error 2% fs | Voltage-free contact, not opto-isolated, typical closing current 6 mA, open contact voltage 13 V, open contact resistance 13 V, max contact resistance 50 Ω. (*) Fast digital input: 0-2 kHz; error 2% fs |
| J3 ID3, ID4, ID5                |   |   |
| J9 ID6 – DIN model only         |   |   |

| <b>Analogue outputs (Lmax=10m)</b> |                        |                        |
|------------------------------------|------------------------|------------------------|
| J14 Y1, Y2                         | 0 to 10 Vdc: 10 mA max | 0 to 10 Vdc: 10 mA max |

### Digital outputs (Lmax=10m)

Note: the sum of current draw on NO1, NO2, NO3 and NO4 must not exceed 8 A

|     |   |   |   |
|-----|---|---|---|
| J6  | NO1 (5 A), NO2 (5 A), NO3 (5 A), NO4 (5A) | 5 A: EN60730: 5 A resistive, 250 Vac, 50k cycles; 4(1), 230 Vac, 100k cycles; 3 (1), 230 Vac, 100k cycles | 5 A: EN60730: 5 A resistive, 250 Vac, 50k cycles; 4(1), 230 Vac, 100k cycles; 3 (1), 230 Vac, 100k cycles |
| J7  | NO5 (5 A)                                 | UL60730: 5 A resist., 250 Vac, 30k cycles; 1FLA, 6LRA, 250 Vac, 30k cycles; Pilot Duty C300, 30k cycles   | UL60730: 5 A resist., 250 Vac, 30k cycles; 1FLA, 6LRA, 250 Vac, 30k cycles; Pilot Duty C300, 30k cycles   |
| J11 | NO6(5A) – DIN model only                  |   |   |

### Probe and terminal power supply (Lmax=10m)

|     |  |  |  |
|-----|--|--|--|
| 5 V |  | 5 Vdc ± 2% to power the 0 to 5 V ratiometric probes. Max current delivered: 35 mA protected against short-circuits | 5 Vdc ± 2% for power supply to 0 to 5 V ratiometric probes Max current delivered: 35 mA protected against short-circuits |
| +V  |  | 8-11 V to power the 4-20 mA current probes. Maximum current delivered: 80 mA protected against short-circuits      | 8-11 V to power the 4-20 mA current probes. Maximum current delivered: 80 mA protected against short-circuits            |
| VL  |  | Not used   | Not used   |
| J8  |  | User terminal power supply   | User terminal power supply   |

### Serial ports

|          |  |   |   |
|----------|--|---|---|
| BMS      |  | Lmax = 500 m, shielded cable (RS485 1½ twisted pair) (1)<br>Integrated<br>Protocol: Modbus<br>HW driver: asynchronous half duplex RS485<br>Not optically-isolated<br>3-pin plug-in connector, 3.81mm pitch<br>Max data rate: 115200 bits/s<br>Maximum number of connectable devices: 16   | Lmax = 500 m, shielded cable (RS485 1½ twisted pair) (1)<br>Integrated<br>Protocol: Modbus<br>HW driver: asynchronous half duplex RS485<br>Not optically-isolated<br>3-pin plug-in connector, 3.81mm pitch<br>Max data rate: 115200 bits/s<br>Maximum number of connectable devices: 16   |
| FieldBus |  | Lmax = 10 m, shielded cable (RS485 1½ twisted pair) (1)<br>Integrated<br>HW driver: asynchronous half duplex RS485 Typical reception resistance 96 kohms, equal to 1/8 of unit load, i.e. 1/256 of maximum load applicable on the row<br>Not optically-isolated<br>Max data rate: 19200 bits/s<br>Maximum number of connectable devices: 16<br>Protocol: ModBus RTU | Lmax = 10 m, shielded cable (RS485 1½ twisted pair) (1)<br>Integrated<br>HW driver: asynchronous half duplex RS485 Typical reception resistance 96 kohms, equal to 1/8 of unit load, i.e. 1/256 of maximum load applicable on the row<br>Not optically-isolated<br>Max data rate: 19200 bits/s<br>Maximum number of connectable devices: 16<br>Protocol: ModBus RTU |

### Cable lengths

|  |  |                            |
|--|--|----------------------------|
| Analogue inputs/outputs, digital inputs/outputs, probe power | < 10m (*) (*) in the panel version, if using the +13 V power supply in domestic environments, the maximum cable length is 2 m. |                            |
| BMS and Fieldbus serial                                      | <500 m with shielded cable   | <500 m with shielded cable |

### Conformity

|   |  |  |
|---|--|--|
| Electrical safety                             | EN/UL 60730-1, EN/UL 60335-1   | EN/UL 60730-1, EN/UL 60335-1   |
| Electromagnetic compatibility                 | EN 61000-6-1, EN 61000-6-2, EN 61000-6-3, EN 61000-6-4               | EN 61000-6-1, EN 61000-6-2, EN 61000-6-3, EN 61000-6-4               |
| Applications with flammable refrigerant gases | EN/UL 60079-15, EN/UL 60335-2-34, EN/UL 60335-2-40, EN/UL 60335-2-89 | EN/UL 60079-15, EN/UL 60335-2-34, EN/UL 60335-2-40, EN/UL 60335-2-89 |
| Wireless compliance                           | RED, FCC, IC   | RED, FCC, IC   |

☞ Notice: (1) it is recommended to use a BELDEN 8761 cable (AWG 22).

## 9.1 Connector/cable table

| Ref. | Description  | Wiring terminals  | Wire cross-section (mm <sup>2</sup> ) | Lmax (m) |
|------|--|---|---------------------------------------|----------|
| J1   | Controller power supply                            | Panel model: removable terminal, screw, 2-pin, pitch 5.08<br>DIN rail model: removable terminal, screw, 2-pin, pitch 5.08 | 0.5 to 1.5<br>0.21 to 3.31            | 10<br>10 |
| J2   | Inputs S1, S2, S3, S5, ID1, ID2;<br>Outputs Y1, Y2 | 10-pin Microfit crimp connector   | 0.05 to 0.52                          | 10       |
| J3   | Inputs S4, S6, ID3, ID4, ID5                       | 8-pin Microfit crimp connector  | 0.05 to 0.52                          | 10       |
| J4   | BMS  | Plug-in screw terminal, 3-pin, pitch 3.81   | 0,081 to 1.31                         | 500      |
| J5   | Fbus   | Plug-in screw terminal, 3-pin, pitch 3.81   | 0,081 to 1.31                         | 10       |
| J6   | Outputs NO1, NO2, NO3, NO4                         | 6-pin Microfit crimp connector  | 0.5 to 1.31                           | 10       |
| J7   | Output NO5   | 3-pin Microfit crimp connector  | 0.5 to 1.31                           | 10       |
| J9   | Inputs S7, ID6                                     | 4-pin Microfit crimp connector  | 0.05 to 0.52                          | 10       |
| J11  | Output NO6   | 3-pin Microfit crimp connector  | 0.5 to 1.31                           | 10       |

## 10. RELEASE NOTES

| REVISION | DATE       | DESCRIPTION                 |
|----------|------------|-----------------------------|
| 1.0.0    | 31.01.2025 | First draft of the document |



# CAREL

---

CAREL INDUSTRIES - Headquarters  
Via dell'Industria, 11 - 35020 Brugine - Padova (Italy)  
Tel. (+39) 049.9716611 - Fax (+39) 049.9716600  
e-mail: [carel@carel.com](mailto:carel@carel.com) - [www.carel.com](http://www.carel.com)

Universal Controller rel. 1.0.0 - 31/01/2025