

HANDBOOK
EXPANSION VALVES FOR REFRIGERATING SYSTEMS



INDEX

Thermostatic expansion valves series 22	07
Pwm solenoid expansion valves	17

FROM QUALITY OUR NATURAL DEVELOPMENT

Achieved the goal of fifty years working in the industry of Refrigeration and Air Conditioning, Castel Quality Range of Products is well known and highly appreciated all over the world. Quality is the main issue of our Company and it has a special priority, in every step, all along the production cycle. UNI EN ISO 9001:2008, issued by ICIM, certifies the Quality System of the Factory. Moreover Castel Products count a number of certifications in conformity with EEC Directives and with European and American Quality Approval. We produce on high tech machinery and updated automatic production lines, operating in conformity with the safety and environment standards currently enforced. Castel offers to the Refrigeration and Air Conditioning Market and to the Manufacturers fully tested products suitable with HCFC and HFC Refrigerants currently used in the Refrigeration & Air Conditioning Industry.



External leakage

All the products illustrated in this Handbook are submitted, one by one, to tightness tests besides to functional tests. Allowable external leakage, measurable during the test, agrees to the definition given in Par. 9.4 of EN 12284 : 2003 Standard:

“During the test, no bubbles shall form over a period of at least one minute when the specimen is immersed in water with low surface tension,...”.

Pressure containment

All the products illustrated in this Handbook, if submitted to hydrostatic test, guarantee a pressure strength at least equal to 1,43 x PS in compliance with the Directive 97/23/EC.

All the products illustrated in this Handbook, if submitted to burst test, guarantee a pressure strength at least equal to 3 x PS according to EN 378-2 : 2008 Standard.

Weights

The weights of the items listed in this Handbook include packaging.

Guarantee

All Castel products are covered by a 12 – months warranty. This warranty covers all products or parts thereof that turn out to be defective within the warranty period. In this case, at his own expenses, the customer shall return the defective item with a detailed description of the claimed defects. The warranty doesn't apply if the defect of Castel products are due to mistakes either by customer or by third parties such wrong installations, use contrary to Castel indications, tampering. In case of defects of its own products, Castel will only replace the defective goods and will not refund damages of any kind.

The technical data shown on this catalogue are indicative. Castel reserves the right to modify the same at any time without any previous notice.

The products listed in this handbook are protected according to the law.

THERMOSTATIC EXPANSION VALVES SERIES 22 WITH INTERCHANGEABLE ORIFICE ASSEMBLY



APPLICATION

Castel thermostatic expansion valves series 22 regulate the flow of refrigerant liquid into evaporators; the liquid injection is controlled by the refrigerant superheat.

The new Castel “22” series are designed to work with interchangeable orifice assembly, to provide flexibility in selection of capacities, and can be used in a wide range of applications as listed below:

- Refrigeration systems (display cases in supermarkets, freezers, ice cream and ice maker machines, transport refrigeration etc).
- Air conditioning systems
- Heat pump systems
- Liquid chillers

which use the following refrigerant fluids: R22, R134a, R404A, R407C ; R507 proper to the Group II (as defined in Article 9, Section 2.2 of Directive 97/23/EC and referred to in Directive 67/548/EEC).

OPERATION

Castel thermostatic expansion valves act as throttle device between the high pressure and the low pressure sides of refrigeration systems and ensure that the rate of refrigerant flow into the evaporator exactly matches the rate of evaporation of liquid refrigerant in the evaporator. If the actual superheat is higher than the set point the valve feeds the evaporator with more liquid refrigerant, if

the actual superheat is lower than the set point the valve decreases the flow of liquid refrigerant to the evaporator. Thus the evaporator is fully utilized and no liquid refrigerant may reach the compressor.

CONSTRUCTION

Castel thermostatic expansion valve series 22 is made up of two parts that must work together: the first is the body, which is the actuator of the regulator, and the second is the orifice, which contains the valve and attends the expansion of the refrigerating fluid.

Body assembly: two parts make it up: the thermostatic (power) element and the body with its inner elements.

The thermostatic element is the motor of the valve; a sensing bulb is connected to the diaphragm assembly by 1.5 meter length of capillary tubing, which transmits bulb pressure to the top of the valve's diaphragm. The sensing bulb pressure is a function of the temperature of the thermostatic charge that is the substance within the bulb. The body is made from forged brass with connection in angle configuration. The interchangeable orifice assembly can be replaced through the inlet connection. A steel rod, inside the body, transfers the diaphragm movement to the plug inside the orifice assembly. When the thermostatic charge pressure increases, the diaphragm will be deflected downward transferring this motion to the plug, which lifts from seat and allows the liquid passing through orifice. A spring opposes the force underneath the diaphragm and the side spindle can adjust its tension. Static superheat increases by turning the side spindle clockwise and decreased by turning the spindle counter clockwise.

The thermostatic element is hardly connected by brazing to the forged brass body to avoid any leakage.

The body assembly can be supplied with internal or external equalizer; both types can also be supplied either with flare connections or with solder connections (outlet and external equalizer if present). The nuts for flare connection type and the inlet-brazing adapter for solder connection type can be ordered separately.

Every body assembly is supplied with a strap, code G9150/R61 that allows fixing the bulb to the pipe. This code can be ordered separately too, as repair kit.

The main parts of body assembly are made with the following materials:

- stainless steel for bulb, capillary tubing, diaphragm casing, diaphragm and rod
- hot forged brass EN 12420 – CW 617N for body
- brass EN 12164 – CW 614N for superheat setting spindle and spring holder
- steel DIN 17223-1 for spring
- copper tube EN 12735-1 – Cu DHP for solder connection

Orifice assembly: interchangeable orifice assembly provides a wide range of capacity from 0,5 up to 15,5 kW (nominal capacity with R22).

The external cartridge contains the following elements: housing, plug (metering device), seat, spring and strainer. The rigid design of orifice assembly and its internal components make sure that plug and seat will withstand all types of critical operations (liquid hammering, cavitation, sudden variation of pressure and temperature contaminants). The spring holds the plug firmly to the seat to ensure the minimum leakage through the valve; for positive shut-off, the installation of a solenoid valve is required. Orifice assemblies are available in these two solutions:

- with conical flanged strainer, for valves with SAE Flare threaded connections.
- with flat flanged strainer, for valves with ODS solder connections, to use with adapter series 2271

Orifice assemblies strainers can be cleaned or exchanged, in this last case it's possible to order separately the following two types of strainers:

- strainer 2290 for valves with SAE Flare threaded connections
- strainer 2290/S for valves with ODS solder connections

THERMOSTATIC CHARGES

Liquid charge: the behaviour of valves with liquid charge is exclusively determined by temperature changes at the bulb and not subject to any cross-ambient interference. They feature a fast response time and thus react quickly in the control circuit. Castel thermostatic expansion valves with liquid charge cannot incorporate MOP functions.

Gas charge: the behaviour of valves with gas charge will be determined by the lowest temperature at any part of the expansion valve (thermostatic element, capillary tube or bulb). If any parts other than the bulb are subjected to the lowest temperature, malfunction of expansion valve may occur (charge migration). Castel thermostatic expansion valves with gas charge always feature MOP functions and include ballasted bulb. Ballast in the bulb has a damping effect on the valve regulation and leads to slow opening and fast closure of the valve.

MOP (Maximum Operating Pressure): this functionality limits the evaporator pressure to a maximum value to protect the compressor from the overload condition (Maximum Operating Pressure). MOP is the evaporating pressure at which the expansion valve will throttle liquid injection into the evaporator and thus prevent the evaporating pressure from rising. Expansion valve operates as superheat control in normal working range and operates as pressure regulator within MOP range. The MOP point will change if the factory superheat setting of the expansion valve is changed. Superheat adjustments influence the MOP point as following:

- increase of superheat → decrease of MOP
- decrease of superheat → increase of MOP

Superheat: this is the controlling parameter of the expansion valve. Superheat, measured at the evaporator outlet, is defined as the difference between actual bulb temperature and the evaporating temperature, deduced from evaporator pressure. In order to prevent liquid refrigerant from entering the compressor, a certain minimum superheat must be maintained. In expansion valve operation the following terms are used:

- **Static superheat:** it's the superheat above that the valve will begin to open. Castel thermo expansion valves are factory preset at the following values:
 - 5 °C for Castel valves without MOP
 - 4°C for Castel valves with MOP with nominal operating conditions (see table 2)
- **Opening superheat:** it's the superheat above the static one required to produce a given valve capacity
- **Operating superheat:** it's the sum of static and opening superheat

Subcooling: it's defined as the difference between the condensing temperature (deduced from condensing pressure) and the actual temperature at inlet valve. Subcooling generally increases the capacity of refrigeration system and may be accounted for when dimensioning an expansion valve. Depending on system design, subcooling may be necessary to prevent flash gas from forming in the liquid line. If flash gas forms in the liquid line, the capacity of expansion valve will be greatly reduced. All capacity tables, in this chapter, are calculated for a subcooling value of 4 °C; if the actual subcooling is higher than 4 °C the valve capacity comes from evaporator capacity divided by the correction factor shown in the tables below every capacity tables.

SELECTION

To correctly select a thermo expansion valve on a refrigerating system, the following design conditions must be available:

- Type of refrigerant
- Evaporator capacity, Q_e
- Evaporating temperature/pressure, T_e / p_e
- Lowest possible condensing temperature/pressure, p_c
- Liquid refrigerant temperature, T_l
- Pressure drop in the liquid line, distributor and evaporator, Δp

The following procedure helps to select the correct valve for the system.

Step 1

Determine the pressure drop across the valve. The pressure drop is calculated by the formula:

$$\Delta p_{tot} = p_c - (p_e + \Delta p)$$

where:

- P_c = condensing pressure
- P_e = evaporating pressure
- Δp = sum of pressure drops in the liquid line, distributor and evaporator

Step 2

Determine required valve capacity. Use the evaporator capacity Q_e to select the required valve capacity at a given evaporating temperature. If necessary, correct the evaporator capacity for subcooling. Subcooling liquid refrigerant entering the evaporator increase the evaporator capacity, so that a smaller valve may be required. The subcooling is calculated by the formula:

$$\Delta T_{\text{sub}} = T_c - T_1$$

From the subcooling corrector factor table find the appropriate corrector factor F_{sub} corresponding to the ΔT_{sub} calculated and determine the required valve capacity by the formula:

$$\Delta Q_{\text{sub}} = \frac{Q_e}{F_{\text{sub}}}$$

Step 3

Determine required orifice size. Use the pressure drop across the valve, the evaporating temperature and the calculated evaporator capacity to select the corresponding orifice size from the capacity table corresponding to the chosen refrigerant.

Step 4

Select a thermostatic charge. Choose the type of charge, liquid without MOP or gas with MOP, and the temperature range, normal temperature or low temperature.

Step 5

Determine if external equalizer is required. External equalizer is always required if a distributor is used or if there is an appreciable difference in pressure from the valve outlet to the bulb location. Finally determine the type of connections and their sizes.

Step 6

Order the required components. If SAE Flare connections you have to order the following two parts:

- Body assembly (see tabs 1a/1b)
- Orifice assembly, completed with strainer (see tab 2)

If ODS connections you have to order the following three parts:

- Body assembly (see tabs 1a/1b)
- Orifice assembly, completed with strainer (see tab 2)
- Solder adapter (see tab. 3)

SIZING EXAMPLE

Type of refrigerant: R134a
Evaporator capacity, Q_e : 6 [kW]

Evaporating temperature/pressure, T_e	-10 [°C]
Lowest possible condensing temperature/pressure, T_c	30 [°C]
Liquid refrigerant temperature, T_l	20 [°C]
Pressure drop in the liquid line, distributor and evaporator, Δp	1,5 [bar]

Step 1

Determine the pressure drop across the valve.

- Condensing pressure at + 30 °C - $P_c = 6,71$ bar
- Evaporating pressure at - 10 °C - $P_e = 1,01$ bar

$$\Delta p_{\text{tot}} = 6,71 - (1,01 + 1,5) = 4,2 \text{ bar}$$

Step 2

Determine required valve capacity.

$$\Delta T_{\text{sub}} = 30 - 20 = 10 \text{ °C}$$

From the subcooling corrector factor table 5b, we find the appropriate corrector factor F_{sub} equal to 1,08 for $\Delta T_{\text{sub}} = 10$ °C. Required valve capacity is:

$$\Delta Q_{\text{sub}} = \frac{6}{1,08} = 5,55 \text{ kW}$$

Step 3

Determine required orifice size.

Using the capacity table for R134a on page 11 with:

- pressure drop across the valve = 4,2 bar
- evaporating temperature = - 10 °C
- calculated evaporator capacity = 5,55 kW

select the corresponding orifice 2205 (N.B. : the expansion valve capacity must be equal or slightly more than the calculated evaporator capacity)

MARKING

Main valve data are indicated on the upper side of the thermostatic element and on the cartridge surface of the orifice assembly.

On the thermostatic element you may find the following data:

- The valve code number
- The refrigerant
- The evaporating temperature range
- The MOP value, if present
- The maximum allowable pressure PS
- The date of production

On the cartridge of orifice assembly you may find the following data:

- The size of the orifice
- The date of production

On the plastic cap of the orifice assembly package the orifice size is marked. The cap can easily be fastened around the valve capillary tube to clearly identify the valve size.

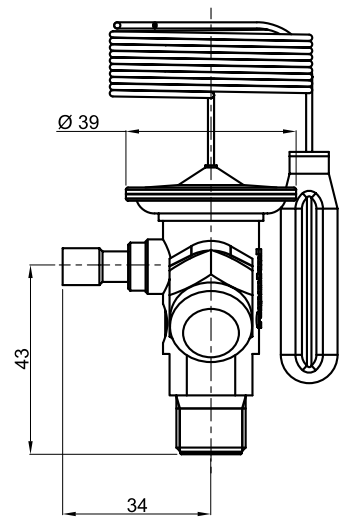
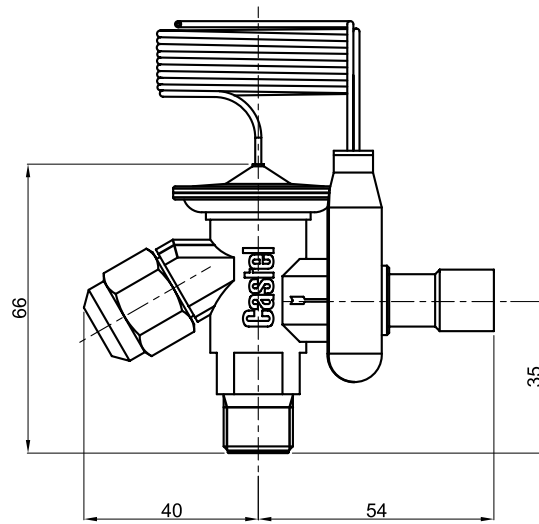
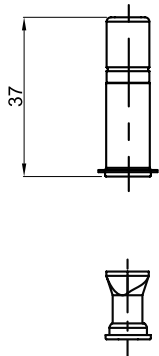
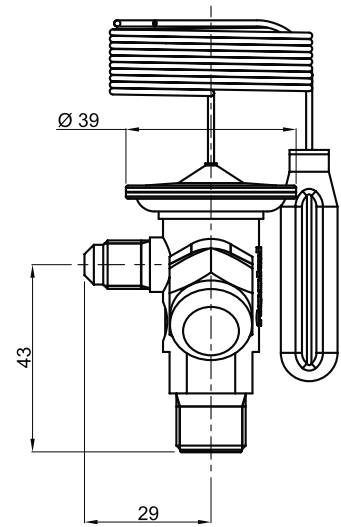
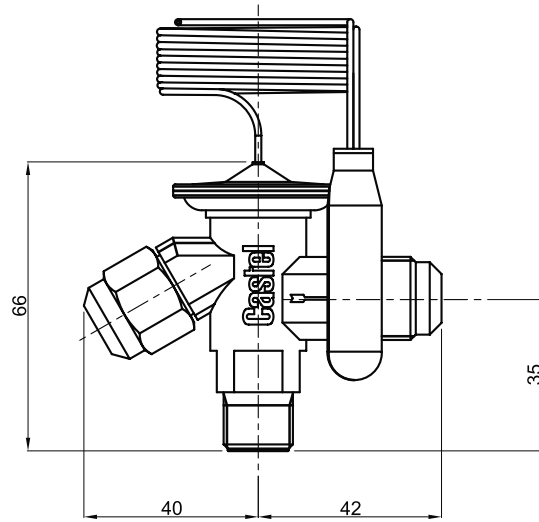
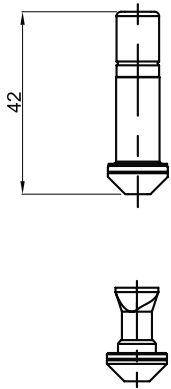

TABLE 1A: General Characteristics of Body Assemblies of Liquid Charge Thermostatic Expansion Valves

Catalogue number		Connections							Refrigerant	Evaporating Temperature Range [°C]	MOP	Max bulb temperature [°C]	TS [°C]		PS [bar]	Risk Category according to PED							
Internal equalizer	External equalizer	SAE Flare			ODS [mm]		ODS [in]																
		IN	OUT	Equal.	OUT	Equal.	OUT	Equal.															
2210/4	-	3/8"	1/2"	-	-	-	-	-	R22 R407C	- 40 → + 10	without	100 (1)	- 60	+ 120	34	Art. 3.3							
2210/M12S			-	12	-	-	-																
2210/4S			-	-	-	1/2"	-																
-	2210/4E	1/2"	1/4"	-	-	-																	
-	2210/M12SE	-	12	6	-	-																	
-	2210/4SE	-	-	1/2"	1/4"	-																	
2220/4	-	3/8"	1/2"	-	-	-	-	R134a									- 40 → + 10	without	100 (1)	- 60	+ 120	34	Art. 3.3
2220/M12S			-	12	-	-	-																
2220/4S			-	-	-	1/2"	-																
-	2220/4E	1/2"	1/4"	-	-	-																	
-	2220/M12SE	-	12	6	-	-																	
-	2220/4SE	-	-	1/2"	1/4"	-																	
2230/4	-	3/8"	1/2"	-	-	-	-		R404A R507	- 40 → + 10	without	100 (1)	- 60	+ 120	34	Art. 3.3							
2230/M12S			-	12	-	-	-																
2230/4S			-	-	-	1/2"	-																
-	2230/4E	1/2"	1/4"	-	-	-																	
-	2230/M12SE	-	12	6	-	-																	
-	2230/4SE	-	-	1/2"	1/4"	-																	

(1) : when valve is installed. 60 °C with element not mounted

TABLE 1B: General Characteristics of Body Assemblies of MOP Charge Thermostatic Expansion Valves

Catalogue number		Connections							Refrigerant	Evaporating Temperature Range [°C]	MOP	Max bulb temperature [°C]	TS [°C]		PS [bar]	Risk Category according to PED							
Internal equalizer	External equalizer	SAE Flare			ODS [mm]		ODS [in]																
		IN	OUT	Equal.	OUT	Equal.	OUT	Equal.															
2211/4	-	3/8"	1/2"	-	-	-	-	R22 R407C	- 40 → + 10	+ 15 °C (95 psi)	100 (1)	- 60	+ 120	34	Art. 3.3								
2211/M12S			-	12	-	-	-																
2211/4S			-	-	-	1/2"	-																
-	2211/4E	1/2"	1/4"	-	-	-																	
-	2211/M12SE	-	12	6	-	-																	
-	2211/4SE	-	-	1/2"	1/4"	-																	
2221/4	-	3/8"	1/2"	-	-	-	-									R134a	- 40 → + 10	+ 15 °C (55 psi)	100 (1)	- 60	+ 120	34	Art. 3.3
2221/M12S			-	12	-	-	-																
2221/4S			-	-	-	1/2"	-																
-	2221/4E	1/2"	1/4"	-	-	-																	
-	2221/M12SE	-	12	6	-	-																	
-	2221/4SE	-	-	1/2"	1/4"	-																	
2231/4	-	3/8"	1/2"	-	-	-	-	R404A R507	- 40 → + 10	+ 15 °C (120 psi)	100 (1)	- 60	+ 120	34	Art. 3.3								
2231/M12S			-	12	-	-	-																
2231/4S			-	-	-	1/2"	-																
-	2231/4E	1/2"	1/4"	-	-	-																	
-	2231/M12SE	-	12	6	-	-																	
-	2231/4SE	-	-	1/2"	1/4"	-																	
2234/4	-	3/8"	1/2"	-	-	-	-									R404A R507	- 60 → - 25	- 20 °C (30 psi)	100 (1)	- 60	+ 120	34	Art. 3.3
2234/M12S			-	12	-	-	-																
2234/4S			-	-	-	1/2"	-																
-	2234/4E	1/2"	1/4"	-	-	-																	
-	2234/M12SE	-	12	6	-	-																	
-	2234/4SE	-	-	1/2"	1/4"	-																	

(1) : when valve is installed. 60 °C with element not mounted

TABLE 2: Orifice Assemblies - Rated Capacities in kW

Catalogue Number		Evaporating Temperature Range [°C]			
Valves with SAE Flare connections	Valves with ODS connections	- 40 → + 10			- 60 → - 25
		R22 R407C	R134a	R404A R507	R404A R507
220X	220X/S	0,5	0,4	0,38	0,38
2200	2200/S	1,0	0,9	0,7	0,7
2201	2201/S	2,5	1,8	1,6	1,6
2202	2202/S	3,5	2,6	2,1	2,1
2203	2203/S	5,2	4,6	4,2	3,5
2204	2204/S	8,0	6,7	6,0	4,9
2205	2205/S	10,5	8,6	7,7	6,0
2206	2206/S	15,5	10,5	9,1	6,6

Rated capacities, for temperature range - 40 → + 10, are based on:

- Evaporating temperature $T_{evap} = + 5 \text{ °C}$
- Condensing temperature $T_{cond} = + 32 \text{ °C}$
- Refrigerant liquid temperature ahead of valve $T_{liq} = + 28 \text{ °C}$

Rated capacities, for temperature range - 60 → - 25, are based on:

- Evaporating temperature $T_{evap} = - 30 \text{ °C}$
- Condensing temperature $T_{cond} = + 32 \text{ °C}$
- Refrigerant liquid temperature ahead of valve $T_{liq} = + 28 \text{ °C}$

TABLE 3: Solder adapters

Catalogue Number	ODS Connections	
	[in]	[mm]
2271/M6S	-	6
2271/2S	1/4"	-
2271/3S	3/8"	-
2271/M10S	-	10

TABLE 4A: Refrigerant R22/R407C - Capacities in kW for temperature range - 40°C → + 10°C

Orifice code	Pressure drop across valve [bar]								Orifice code	Pressure drop across valve [bar]							
	2	4	6	8	10	12	14	16		2	4	6	8	10	12	14	16
Evaporating temperature = + 10 °C									Evaporating temperature = 0 °C								
220X	0,37	0,48	0,55	0,60	0,63	0,65	0,65	0,67	220X	0,37	0,48	0,55	0,59	0,63	0,65	0,66	0,66
2200	0,87	1,1	1,2	1,3	1,4	1,4	1,4	1,5	2200	0,84	1,0	1,2	1,3	1,3	1,4	1,4	1,4
2201	2,2	2,8	3,2	3,4	3,6	3,7	3,8	3,8	2201	1,9	2,4	2,7	3,0	3,1	3,2	3,3	3,3
2202	3,0	4,0	4,7	5,1	5,4	5,6	5,8	5,8	2202	2,6	3,4	4,0	4,3	4,6	4,8	4,9	5,0
2203	5,4	7,2	8,3	9,1	9,7	10,0	10,2	10,3	2203	4,6	6,1	7,1	7,8	8,2	8,5	8,7	8,8
2204	8,1	10,8	12,5	13,8	14,5	15,0	15,5	15,5	2204	6,9	9,1	10,5	11,5	12,2	12,7	13,0	13,2
2205	10,2	13,6	15,7	17,2	18,3	18,9	19,3	19,5	2205	8,8	11,6	13,3	14,6	15,5	16,1	16,4	16,6
2206	12,6	16,7	19,3	21,0	22,3	23,1	23,5	23,7	2206	10,8	14,2	16,3	17,8	18,9	19,6	20,0	20,2
Evaporating temperature = - 10 °C									Evaporating temperature = - 20 °C								
220X	0,37	0,47	0,53	0,57	0,60	0,63	0,64	0,64	220X		0,44	0,50	0,54	0,57	0,59	0,61	0,61
2200	0,79	0,96	1,1	1,2	1,2	1,3	1,3	1,3	2200		0,88	1,0	1,1	1,1	1,2	1,2	1,2
2201	1,6	2,0	2,3	2,5	2,6	2,7	2,8	2,8	2201		1,7	1,9	2,0	2,2	2,3	2,3	2,3
2202	2,2	2,9	3,3	3,6	3,8	4,0	4,1	4,1	2202		2,4	2,7	2,9	3,1	3,2	3,3	3,3
2203	3,9	5,1	5,9	6,4	6,8	7,1	7,3	7,3	2203		4,2	4,8	5,2	5,5	5,8	5,9	6,0
2204	5,8	7,6	8,7	9,5	10,1	10,5	10,8	10,9	2204		6,2	7,1	7,7	8,2	8,5	8,7	8,8
2205	7,4	9,6	11,0	12,0	12,8	13,3	13,6	13,8	2205		7,9	9,0	9,8	10,3	10,8	11,0	11,2
2206	9,1	11,6	13,5	14,7	15,6	16,2	16,6	16,8	2206		9,6	11,0	11,9	12,6	13,1	13,5	13,7
Evaporating temperature = - 30 °C									Evaporating temperature = - 40 °C								
220X		0,40	0,45	0,49	0,52	0,55	0,56	0,57	220X			0,42	0,45	0,48	0,50	0,52	0,53
2200		0,79	0,9	0,96	1,0	1,1	1,1	1,1	2200			0,8	0,86	0,92	0,95	0,98	0,99
2201		1,4	1,5	1,7	1,8	1,8	1,9	1,9	2201			1,3	1,4	1,4	1,5	1,5	1,6
2202		1,9	2,2	2,7	2,5	2,6	2,6	2,7	2202			1,7	1,9	2,0	2,0	2,1	2,1
2203		3,4	3,9	4,2	4,4	4,6	4,7	4,8	2203			3,1	3,4	3,5	3,7	3,8	3,8
2204		5,0	5,7	6,2	6,6	6,8	7,0	7,1	2204			4,6	4,9	5,2	5,4	5,6	5,7
2205		6,4	7,2	7,8	8,3	8,6	8,8	9,0	2205			5,8	6,3	6,6	6,9	7,1	7,2
2206		7,8	8,8	9,6	10,1	10,5	10,8	11,0	2206			7,1	7,7	8,1	8,4	8,7	8,8

TABLE 4B: Refrigerant R22/R407C - Correction factor for subcooling $\Delta t_{sub} > 4^\circ\text{C}$

Δt_{sub} [°C]	4	10	15	20	25	30	35	40	45	50
F_{sub}	1,00	1,06	1,11	1,15	1,20	1,25	1,30	1,35	1,39	1,44

When subcooling ahead of the expansion valve is other than 4 °C , adjust the evaporatore capacity by dividing by the appropriate correction factor found in Table 4B.

TABLE 5A: Refrigerant R134a - Capacities in kW for temperature range - 40°C → + 10°C

Orifice code	Pressure drop across valve [bar]					Orifice code	Pressure drop across valve [bar]				
	2	4	6	8	10		2	4	6	8	10
Evaporating temperature = + 10 °C						Evaporating temperature = 0 °C					
220X	0,34	0,43	0,47	0,50	0,51	220X	0,33	0,42	0,46	0,47	0,49
2200	0,71	0,86	0,93	0,97	0,98	2200	0,65	0,78	0,86	0,89	0,91
2201	1,5	1,9	2,1	2,2	2,2	2201	1,3	1,6	1,7	1,8	1,8
2202	2,0	2,6	3,0	3,1	3,2	2202	1,7	2,2	2,4	2,6	2,6
2203	3,6	4,7	5,3	5,6	5,8	2203	3,0	3,9	4,4	4,6	4,7
2204	5,4	7,0	7,8	8,3	8,6	2204	4,5	5,7	6,4	6,8	7,0
2205	6,9	8,9	9,9	10,8	10,9	2205	5,7	7,3	8,1	8,6	8,8
2206	8,4	10,8	12,1	12,8	13,2	2206	7,0	8,9	1,0	10,5	10,8
Evaporating temperature = - 10 °C						Evaporating temperature = - 20 °C					
220X	0,30	0,36	0,43	0,44	0,44	220X	0,28	0,35	0,39	0,41	0,42
2200	0,59	0,70	0,77	0,81	0,82	2200	0,53	0,62	0,69	0,72	0,73
2201	1,0	1,3	1,4	1,5	1,5	2201	0,81	1,0	1,1	1,2	1,2
2202	1,4	1,8	2,0	2,1	2,1	2202	1,1	1,4	1,5	1,6	1,7
2203	2,5	3,1	3,5	3,7	3,8	2203	2,0	2,5	2,8	2,9	3,0
2204	3,6	4,6	5,1	5,4	5,6	2204	2,9	3,6	4,0	4,3	4,4
2205	4,6	5,8	6,5	6,9	7,1	2205	3,7	4,6	5,1	5,4	5,5
2206	5,7	7,1	8,0	8,4	8,6	2206	4,5	5,6	6,2	6,6	6,8
Evaporating temperature = - 30 °C						Evaporating temperature = - 40 °C					
220X	0,25	0,32	0,35	0,37	0,38	220X	0,23	0,28	0,32	0,33	0,34
2200	0,48	0,55	0,61	0,64	0,64	2200	0,44	0,50	0,54	0,56	0,57
2201	0,66	0,80	0,88	0,93	0,95	2201	0,54	0,65	0,72	0,78	0,77
2202	0,9	1,1	1,2	1,3	1,3	2202	0,7	0,9	1,0	1,0	1,0
2203	1,6	2,0	2,2	2,3	2,3	2203	1,3	1,6	1,8	1,9	1,9
2204	2,3	2,9	3,2	3,3	3,4	2204	1,9	2,3	2,6	2,7	2,7
2205	3,0	3,6	4,0	4,2	4,3	2205	2,4	2,9	3,2	3,5	3,5
2206	3,6	4,4	4,9	5,2	5,3	2206	3,0	3,6	4,0	4,2	4,3

TABLE 5B: Refrigerant R134a - Correction factor for subcooling $\Delta t_{sub} > 4^\circ\text{C}$

Δt_{sub} [°C]	4	10	15	20	25	30	35	40	45	50
F_{sub}	1,00	1,08	1,13	1,19	1,25	1,31	1,37	1,42	1,48	1,54

When subcooling ahead of the expansion valve is other than 4 °C , adjust the evaporator capacity by dividing by the appropriate correction factor found in Table 5B.

TABLE 6A: Refrigerant R404A/R507 - Capacities in kW for temperature range - 40°C → + 10°C

Orifice code	Pressure drop across valve [bar]								Orifice code	Pressure drop across valve [bar]							
	2	4	6	8	10	12	14	16		2	4	6	8	10	12	14	16
Evaporating temperature = + 10 °C									Evaporating temperature = 0 °C								
220X	0,28	0,35	0,40	0,42	0,43	0,43	0,42	0,41	220X	0,30	0,37	0,41	0,42	0,43	0,43	0,43	0,41
2200	0,67	0,82	0,90	0,94	0,96	0,96	0,93	0,90	2200	0,68	0,80	0,87	0,90	0,92	0,93	0,91	0,87
2201	1,70	2,10	2,30	2,42	2,48	2,46	2,41	2,34	2201	1,53	1,86	2,04	2,13	2,18	2,18	2,15	2,08
2202	2,32	3,00	3,39	3,61	3,73	3,74	3,68	3,59	2202	2,06	2,64	2,95	3,13	3,22	3,25	3,21	3,11
2203	4,15	5,36	6,03	6,43	6,63	6,66	6,55	6,39	2203	3,68	4,72	5,27	5,59	5,75	5,80	5,73	5,55
2204	6,24	8,06	9,06	9,66	9,95	9,98	9,81	9,57	2204	5,49	7,15	7,86	8,33	8,58	8,64	8,53	8,27
2205	7,91	10,17	11,43	12,16	12,53	12,56	12,34	12,03	2205	6,97	8,92	9,95	10,52	10,83	10,90	10,76	10,43
2206	9,71	12,47	13,98	14,86	15,29	15,31	15,05	14,66	2206	8,57	10,93	12,16	12,85	13,21	13,30	13,12	12,72
Evaporating temperature = - 10 °C									Evaporating temperature = - 20 °C								
220X	0,30	0,37	0,40	0,42	0,42	0,42	0,41	0,41	220X		0,35	0,38	0,40	0,39	0,40	0,39	0,38
2200	0,65	0,76	0,82	0,84	0,87	0,87	0,85	0,83	2200		0,70	0,75	0,77	0,79	0,79	0,79	0,76
2201	1,31	1,61	1,74	1,81	1,84	1,85	1,84	1,78	2201		1,34	1,45	1,50	1,52	1,52	1,51	1,47
2202	1,76	2,24	2,50	2,62	2,69	2,71	2,68	2,60	2202		1,85	2,04	2,14	2,17	2,18	2,16	2,09
2203	3,14	4,02	4,47	4,69	4,81	4,84	4,79	4,65	2203		3,32	3,66	3,83	3,89	3,90	3,86	3,75
2204	4,66	5,97	6,61	6,95	7,13	7,18	7,11	6,91	2204		4,88	5,40	5,64	5,75	5,77	5,71	5,56
2205	5,93	7,57	8,39	8,81	9,02	9,08	8,99	8,73	2205		6,20	6,86	7,17	7,29	7,31	7,23	7,05
2206	7,28	9,27	10,26	10,76	11,00	11,08	10,97	10,65	2206		7,60	8,39	8,75	8,91	8,93	8,84	8,61
Evaporating temperature = - 30 °C									Evaporating temperature = - 40 °C								
220X			0,35	0,37	0,36	0,37	0,36	0,35	220X			0,32	0,33	0,33	0,33	0,32	0,32
2200			0,67	0,70	0,70	0,70	0,69	0,67	2200			0,60	0,61	0,62	0,61	0,60	0,59
2201			1,18	1,21	1,23	1,21	1,20	1,17	2201			0,92	0,96	0,97	0,96	0,94	0,91
2202			1,63	1,69	1,71	1,70	1,68	1,64	2202			1,27	1,32	1,33	1,31	1,28	1,24
2203			2,93	3,04	3,07	3,06	3,02	2,93	2203			2,28	2,36	2,38	2,36	2,31	2,24
2204			4,28	4,47	4,52	4,51	4,46	4,35	2204			3,34	3,47	3,50	3,48	3,42	3,33
2205			5,45	5,68	5,74	5,74	5,67	5,52	2205			4,25	4,41	4,45	4,43	4,36	4,24
2206			6,66	6,94	7,02	7,01	6,93	6,75	2206			5,19	5,39	5,45	5,42	5,33	5,19

TABLE 6B: Refrigerant R404A/R507 - Correction factor for subcooling $\Delta t_{sub} > 4^\circ\text{C}$

Δt_{sub} [°C]	4	10	15	20	25	30	35	40	45	50
F_{sub}	1,00	1,10	1,20	1,29	1,37	1,46	1,54	1,63	1,70	1,78

When subcooling ahead of the expansion valve is other than 4 °C , adjust the evaporator capacity by dividing by the appropriate correction factor found in Table 6B.

TABLE 7A: Refrigerant R404A/R507 - Capacities in kW for temperature range - 60°C → - 25°C

Orifice code	Pressure drop across valve [bar]								Orifice code	Pressure drop across valve [bar]							
	2	4	6	8	10	12	14	16		2	4	6	8	10	12	14	16
Evaporating temperature = - 25 °C									Evaporating temperature = - 30 °C								
2200	0,57	0,67	0,72	0,73	0,74	0,85	0,74	0,71	2200	0,53	0,64	0,67	0,70	0,70	0,70	0,69	0,67
2201	0,98	1,20	1,31	1,36	1,37	1,37	1,35	1,31	2201	0,88	1,07	1,18	1,21	1,23	1,21	1,20	1,17
2202	1,31	1,65	1,83	1,91	1,93	1,93	1,90	1,85	2202	1,18	1,47	1,63	1,69	1,71	1,70	1,68	1,64
2203	2,35	2,97	3,28	3,42	3,47	3,46	3,42	3,32	2203	2,12	2,65	2,93	3,04	3,07	3,05	3,02	2,93
2204	3,45	4,37	4,82	5,04	5,11	5,12	5,06	4,93	2204	3,09	3,88	4,28	4,47	4,52	4,51	4,46	4,35
2205	4,40	5,56	6,14	6,40	6,49	6,49	6,42	6,26	2205	3,94	4,94	5,45	5,68	5,74	5,74	5,67	5,52
2206	5,40	6,30	7,49	7,81	7,93	7,93	7,85	7,64	2206	4,83	6,06	6,66	6,94	7,02	7,01	6,93	6,75
Evaporating temperature = - 40 °C									Evaporating temperature = - 50 °C								
2200		0,56	0,60	0,61	0,62	0,61	0,60	0,59	2200		0,49	0,53	0,54	0,54	0,53	0,52	0,50
2201		0,65	0,72	0,75	0,77	0,77	0,77	0,75	2201		0,51	0,57	0,60	0,60	0,60	0,60	0,59
2202		1,17	1,27	1,32	1,33	1,31	1,28	1,24	2202		0,91	0,99	1,02	1,02	1,01	0,98	0,95
2203		2,09	2,28	2,36	2,38	2,36	2,31	2,24	2203		1,63	1,73	1,84	1,84	1,81	1,78	1,72
2204		3,03	3,34	3,47	3,50	3,48	3,42	3,33	2204		2,36	2,60	2,69	2,71	2,68	2,63	2,56
2205		3,87	4,25	4,41	4,45	4,43	4,36	4,24	2205		3,02	3,30	3,43	3,45	3,42	3,35	3,26
2206		4,73	5,19	5,39	5,45	5,47	5,33	5,19	2206		3,69	4,04	4,20	4,22	4,18	4,12	4,00
Evaporating temperature = - 60 °C																	
2200			0,46	0,48	0,47	0,45	0,45	0,43									
2201			0,58	0,60	0,60	0,58	0,56	0,54									
2202			0,78	0,80	0,80	0,78	0,75	0,72									
2203			1,40	1,44	1,43	1,40	1,36	1,30									
2204			2,04	2,11	2,11	2,07	2,03	1,96									
2205			2,59	2,69	2,66	2,65	2,59	2,50									
2206			3,16	3,28	3,30	3,25	3,18	3,07									

TABLE 7B: Refrigerant R404A/R507 - Correction factor for subcooling $\Delta t_{sub} > 4^\circ\text{C}$

Δt_{sub} [°C]	4	10	15	20	25	30	35	40	45	50
F_{sub}	1,00	1,10	1,20	1,29	1,37	1,46	1,54	1,63	1,70	1,78

When subcooling ahead of the expansion valve is other than 4 °C , adjust the evaporator capacity by dividing by the appropriate correction factor found in Table 7B.

PWM SOLENOID EXPANSION VALVE WITH INTERCHANGEABLE ORIFICE



APPLICATION

Solenoid expansion valve Castel type 2028 regulates the refrigerant flow into the evaporator by modulating the opening time phase of the plug and so permitting a wide range of power.

This valve must be used with a coil type HM4 (see table 2), controlled by an electronic regulator device (not supplied by Castel).

This valve is most frequently used in refrigeration systems, in particular refrigerated cabinets in the supermarket, which use the following refrigerant fluids: R22, R134a, R404A, R407C ; R410A, R507 proper to the Group II (as defined in Article 9, Section 2.2 of Directive 97/23/EC and referred to in Directive 67/548/EEC).

OPERATION

Valve type 2028 is a lamination device that receives liquid from the condenser and injects it into the evaporator, operating the necessary pressure drop across the expansion orifice.

It's an ON/OFF valve that must be regulated with the **Pulse Width Modulation (PWM)** method and it can be actuated by a very simple electronic controller. In according to the PWM method, the evaporator refrigerant capacity Q_T , required in a fixed period "T", is delivered by the valve in a time interval "t", shorter than "T". During the period "t" the

valve opens and permits maximum flow (ON phase); in the remaining period "T-t" the valve closes with no flow (OFF phase).

For an effective PWM regulation, the valve must be sized in such a way that in the hardest conditions of the system, the orifice of the valve is big enough to deliver the refrigerant requested; in these extreme conditions the valve will last opened for the entire period "T".

The use of an electronic regulator allows a more accurate metering of the refrigerant reaching a greater efficiency (and then a sensible decrement of the machinery management costs) and a faster response to the variations of the evaporation load.

CONSTRUCTION

Valve is supplied complete with its orifice; there are nine different orifices corresponding to seven different evaporator capacities that increase passing from orifice 01 to orifice 09. The last two numbers in the code identify what size of orifice has been mounted on the valve into the factory; for example the code 2028/3S02 identifies a valve with 3/8" solder connections, size 02 orifice. The orifices are interchangeable and can be mounted even if the valve is soldered on the system; in this case use the corresponding spare parts kit, in according to table 3.

The main parts of the valves are made with the following materials:

- Hot forged brass EN 12420 – CW 617N for body and the housing pipe of the mobile plug
- Copper tube EN 12735-1 – Cu-DHP for solder connections
- Austenitic stainless steel EN 10088-3 – 1.4301 for the filter
- Ferritic stainless steel EN 10088-3 – 1.4105 for mobile and fixed plugs
- Austenitic stainless steel EN 10088-3 – 1.4305 for orifices
- Chloroprene rubber (CR) for outlet seal gaskets
- P.T.F.E. for seat gaskets

COILS AND CONNECTORS

Coils type HM4 must be mounted on these valves. Table 2 presents the most important characteristics of coils and corresponding connectors. For further technical characteristics about HM4 coils and their connectors see to the "Solenoid valve" handbook.

SELECTION

To correctly select a solenoid expansion valve on a refrigerating system, the following design conditions must be available:

- Type of refrigerant
- Evaporator capacity, Q_e

- Temperatura/pressione d'evaporazione; T_e / p_e
- Lowest possible condensing temperature/pressure, T_c / p_c
- Liquid refrigerant temperature, T_l
- Pressure drop in the liquid line, distributor and evaporator, Δp

The following procedure helps to select the correct valve for the system.

Step 1

Determine the pressure drop across the valve. The pressure drop is calculated by the formula:

$$\Delta p_{tot} = p_c - (p_e + \Delta p)$$

where:

- P_c = condensing pressure
- P_e = evaporating pressure
- Δp = sum of pressure drops in the liquid line, distributor and evaporator

Step 2

Subcooling correction. Use the evaporating capacity Q_e to select the required valve size at a given evaporating temperature. If necessary, correct the evaporator capacity for subcooling. Subcooling liquid refrigerant entering the evaporator increase the evaporator capacity, so that a smaller valve may be required. e subcooling is calculated by the formula:

$$\Delta T_{sub} = T_c - T_l$$

From the subcooling corrector factor table find the appropriate corrector factor F_{sub} corresponding to the ΔT_{sub} calculated and determine the required valve capacity by the formula:

$$Q_{sub} = F_{sub} \times Q_e$$

Step 3

Application correction. To obtain a correct regulation with this valve, is necessary to oversize it so its closing period is between the 25% and the 50% of the total period T of the regulator. The correct choice of this closing period depends on the application that can have peaks of load and on the criterion used by the electronic regulator.

Generally, anyway, this correcting factor F_{ev} is strictly dependent by the evaporation temperature so it be assumed that $F_{ev} = 1.25$ for $T_{ev} \geq -15^\circ\text{C}$ and $F_{ev} = 1.50$ for $T_{ev} < -15^\circ\text{C}$. These generic instructions must be verified on the real application.

$$Q_{ev} = F_{ev} \times Q_{sub}$$

Step 4

Determine required orifice size. Use the pressure drop across the valve, the evaporating temperature and the calculated

evaporator capacity Q_e to select the corresponding orifice size from the capacity table corresponding to the chosen refrigerant.

Step 5

Liquid line sizing. Since the 2028 is an ON/OFF valve, during the opening phase of the valve, the flow rate can be too much higher than the mean flow rate. For this reason the designer must size the diameter of the pipes of the liquid line in according to the maximum flow rate across the orifice in the effective conditions of Δp_{tot} and so avoiding the decrement of the valve capacity due to the pressure drop.

SIZING EXAMPLE

Type of refrigerant:	R404A
Evaporator capacity, Q_e	2,8 [kW]
Evaporating temperature/pressure, T_e	-5 [°C]
Lowest possible condensing temperature/pressure, T_c	35 [°C]
Liquid refrigerant temperature, T_l	20 [°C]
Pressure drop in the liquid line, distributor and evaporator, Δp	2 [bar]

Step 1

Determine the pressure drop across the valve.

- Condensing pressure at + 35 °C - $P_c = 16,9$ bar
- Evaporating pressure at - 5 °C - $P_e = 5,14$ bar

$$\Delta p_{tot} = 16,9 - (5,14 + 2) = 9,76 \text{ bar}$$

Step 2

Determine required valve capacity.

$$\Delta T_{sub} = 35 - 20 = 15 \text{ °C}$$

From the subcooling corrector factor table 9, we find the appropriate corrector factor F_{sub} equal to 0,83 for $\Delta T_{sub} = 15$ °C. Required valve capacity is:

$$Q_{sub} = 0,83 \times 2,8 = 2,324 \text{ kW}$$

Step 3

Determine application correction. In according to the above criterion of sizing, $F_{ev} = 1,25$:

$$Q_{ev} = 1,25 \times 2,324 = 2,91 \text{ kW}$$

Step 4

Determine orifice size. Using the capacity table for R404A on page 17 with:

- pressure drop across the valve = 9,76 bar
- evaporating temperature = - 5 °C
- calculated evaporator capacity = 2,91 kW

select the corresponding orifice size 04 (N.B. : the expansion valve capacity must be equal or slightly more than the calculated evaporator capacity)

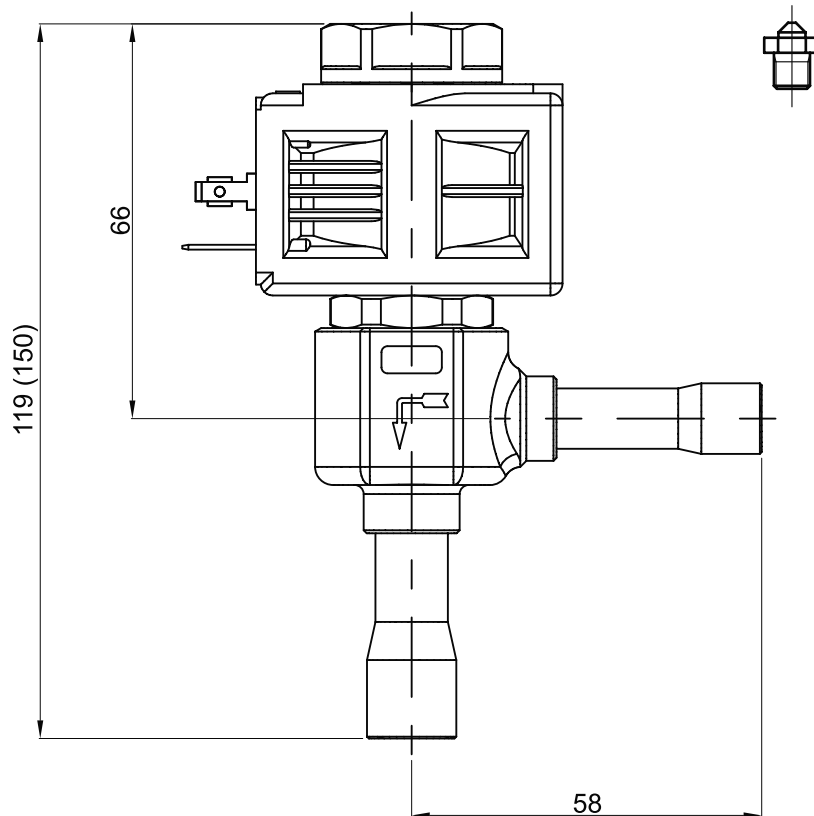

TABLE 1: General Characteristics of PWM Expansion Valves

Catalogue number	ODS Connections				Orifice Size [mm]	Kv Factor [m³/h]	Opening Pressure Differential [bar]			Operating principles	Minimum Working Time [s]	TS [°C]		PS [bar]	Risk Category according to PED
	[in]		[mm]				MinOPD	MOPD				min.	max.		
	IN	OUT	IN	OUT				AC	DC						
2028/3S01	3/8"	1/2"	-	-	0,5	0,010	0	18	PWM (Pulse Width Modulating)	1	-40	100	45	Art. 3.3	
2028/M10S01	-	-	10	12											
2028/3S02	3/8"	1/2"	-	-	0,7	0,017									
2028/M10S02	-	-	10	12											
2028/3S03	3/8"	1/2"	-	-	0,8	0,023									18
2028/M10S03	-	-	10	12											
2028/3S04	3/8"	1/2"	-	-	1,1	0,043									
2028/M10S04	-	-	10	12											
2028/3S05	3/8"	1/2"	-	-	1,3	0,065		14							
2028/M10S05	-	-	10	12											
2028/3S06	3/8"	1/2"	-	-	1,7	0,113									
2028/M10S06	-	-	10	12											
2028/4S07	1/2"	5/8"	-	-	2,3	0,200	10								
2028/M12S07	-	-	12	16											
2028/4S08	1/2"	5/8"	-	-	2,5	0,230									
2028/M12S08	-	-	12	16											
2028/4S09	1/2"	5/8"	-	-	2,7	0,250									
2028/M12S09	-	-	12	16											

TABLE 2: General Characteristics of coils

Coil Type	Catalogue Number	Voltage [V]	Voltage tolerance [%]	Frequency [Hz]	Consumption at 20 °C [mA]				Connections	
					Start		Working		Protection Degree IP65	Protection Degree IP65/IP68
					50 [Hz]	D.C.	50 [Hz]	D.C.		
HM4	9160/RA2	24 A.C.	+6 / -10	50	1490	-	700	-	9150/R02	9155/R01
	9160/RA4	110 A.C.			330		156			
	9160/RA6	220/230 A.C.			162		76			
	9160/RD1	12 D.C.	-	1350	1350					
	9160/RD2	24 D.C.		650	650					

TABLE 3: Orifices - Rated capacities in kW

Catalogue number	Orifice Type	Orifice Size [mm]	Refrigerant				
			R22	R134a	R404A R507	R407C	R410A
9150/R63	01	0,5	1,0	0,9	0,8	1,1	1,3
9150/R64	02	0,7	1,9	1,7	1,6	2,0	2,4
9150/R65	03	0,8	2,5	2,0	1,9	2,4	3,0
9150/R66	04	1,1	3,9	3,2	2,9	3,8	4,8
9150/R67	05	1,3	6,7	5,6	5,1	6,7	8,4
9150/R68	06	1,7	9,2	7,7	7,0	9,1	11,4
9150/R69	07	2,3	14,7	12,2	11,3	15,3	18,2
9150/R78	08	2,5	17,4	14,7	13,5	17,7	21,6
9150/R79	09	2,7	19,3	16,3	15,0	19,6	24,1

Rated capacities are based on:

- Evaporating temperature $T_{evap} = + 5 \text{ }^{\circ}\text{C}$
- Condensing temperature $T_{cond} = + 32 \text{ }^{\circ}\text{C}$
- Refrigerant liquid temperature ahead of valve $T_{liq} = + 28 \text{ }^{\circ}\text{C}$

TABLE 4: Refrigerant R22 - Capacities in kW

Orifice Type	Pressure drop across valve [bar]								
	2	4	6	8	10	12	14	16	18
01	0,7	0,9	1,0	1,1	1,1	1,1	1,2	1,2	1,2
02	1,3	1,7	1,9	2,1	2,2	2,2	2,3	2,3	2,3
03	1,7	2,2	2,5	2,7	2,8	2,9	2,9	3,0	3,0
04	2,7	3,5	3,9	4,2	4,4	4,5	4,6	4,7	4,7
05	4,7	6,0	6,7	7,3	7,6	7,8	7,9	8,1	8,1
06	6,4	8,3	9,2	9,9	10,4	10,6	10,8	11,0	11,0
07	10,3	13,2	14,7	15,8	16,6	17,0	17,3	17,6 (1)	17,6 (2)
08	12,2	15,7	17,4	18,8	19,7	20,2	20,5	20,9 (1)	20,9 (2)
09	13,5	17,4	19,3	20,8	21,8	22,4 (1)	22,8 (2)	23,2 (2)	23,2 (2)

TABLE 5: Refrigerante R134a - Potenzialità in kW

Orifice Type	Pressure drop across valve [bar]								
	2	4	6	8	10	12	14	16	18
01	0,6	0,8	0,9	0,9	1,0	1,0	1,0	1,0	0,9
02	1,2	1,5	1,7	1,8	1,8	1,9	1,9	1,8	1,8
03	1,4	1,8	2,0	2,1	2,2	2,2	2,2	2,2	2,1
04	2,3	2,9	3,2	3,5	3,6	3,6	3,6	3,6	3,5
05	3,9	5,0	5,6	6,0	6,1	6,2	6,2	6,1	6,0
06	5,4	6,9	7,7	8,2	8,4	8,5	8,5	8,4	8,2
07	8,5	10,9	12,2	13,0	13,4	13,5	13,5	13,4 (1)	13,0 (2)
08	10,3	13,2	14,7	15,7	16,2	16,3	16,3	16,2 (1)	15,7 (2)
09	11,4	14,7	16,3	17,4	17,9	18,1 (1)	18,1 (2)	17,9 (2)	17,4 (2)

(1) : differential pressure non available with coils 9160/RD2

(2) : differential pressure non available with coils 9160/RD1 and 9160/RD2

TABLE 6: Refrigerant R404A/R507 - Capacities in kW

Orifice Type	Pressure drop across valve [bar]								
	2	4	6	8	10	12	14	16	18
01	0,6	0,7	0,8	0,8	0,8	0,8	0,8	0,8	0,8
02	1,1	1,4	1,6	1,7	1,7	1,7	1,7	1,6	1,5
03	1,3	1,7	1,9	2,0	2,1	2,1	2,0	2,0	1,9
04	2,1	2,7	2,9	3,1	3,2	3,2	3,2	3,1	2,9
05	3,7	4,7	5,1	5,5	5,6	5,6	5,5	5,4	5,1
06	5,0	6,4	7,0	7,4	7,6	7,6	7,5	7,4	6,9
07	8,0	10,2	11,3	11,9	12,2	12,2	12,0	11,8 (1)	11,1 (2)
08	9,6	12,3	13,5	14,3	14,6	14,6	14,4	14,2 (1)	13,4 (2)
09	10,7	13,7	15,0	15,9	16,2	16,2 (1)	16,0 (2)	15,8 (2)	14,9 (2)

TABLE 7: Refrigerant R407C - Capacities in kW

Orifice Type	Pressure drop across valve [bar]								
	2	4	6	8	10	12	14	16	18
01	0,8	1,0	1,1	1,2	1,2	1,3	1,3	1,3	1,3
02	1,4	1,8	2,0	2,2	2,3	2,4	2,4	2,4	2,4
03	1,7	2,1	2,4	2,6	2,7	2,8	2,8	2,9	2,9
04	2,7	3,4	3,8	4,1	4,3	4,4	4,5	4,6	4,6
05	4,7	6,0	6,7	7,3	7,6	7,8	7,9	8,1	8,1
06	6,4	8,2	9,1	9,8	10,3	10,5	10,7	10,9	10,9
07	10,7	13,8	15,3	16,5	17,3	17,7	18,1	18,4 (1)	18,4 (2)
08	12,4	15,9	17,7	19,1	20,0	20,5	20,9	21,2 (1)	21,2 (2)
09	13,7	17,6	19,6	21,2	22,1	22,7 (1)	23,1 (2)	23,5 (2)	23,5 (2)

(1) : differential pressure non available with coils 9160/RD2

(2) : differential pressure non available with coils 9160/RD1 and 9160/RD2

TABLE 8: Refrigerant R410A - Capacities in kW

Orifice Type	Pressure drop across valve [bar]								
	2	4	6	8	10	12	14	16	18
01	0,9	1,1	1,3	1,4	1,5	1,5	1,6	1,6	1,6
02	1,6	2,1	2,4	2,6	2,8	2,9	2,9	3,0	3,0
03	2,0	2,7	3,0	3,3	3,5	3,6	3,7	3,8	3,8
04	3,2	4,3	4,8	5,3	5,6	5,8	5,9	6,1	6,1
05	5,6	7,4	8,4	9,2	9,7	10,0	10,2	10,5	10,6
06	7,7	10,1	11,4	12,5	13,1	13,6	13,9	14,3	14,4
07	12,2	16,0	18,2	19,8	20,9	21,6	22,2	22,7 (1)	22,9 (2)
08	14,5	19,0	21,6	23,5	24,8	25,7	26,4	27,0 (1)	27,2 (2)
09	16,1	21,2	24,1	26,3	27,7	28,7 (1)	29,4 (2)	30,1 (2)	30,4 (2)

(1) : differential pressure non available with coils 9160/RD2

(2) : differential pressure non available with coils 9160/RD1 and 9160/RD2

TABLE 9: Correction factor for subcooling $\Delta t_{sub} > 4^{\circ}\text{C}$

Refrigerants	4K	10K	15K	20K	25K	30K	35K	40K	45K	50K
R22	1	0,94	0,9	0,87	0,83	0,8	0,77	0,74	0,72	0,69
R134a	1	0,93	0,88	0,84	0,8	0,76	0,73	0,7	0,68	0,65
R404A/R507	1	0,91	0,83	0,78	0,73	0,68	0,65	0,61	0,59	0,56
R407C	1	0,93	0,88	0,83	0,79	0,75	0,72	0,69	0,66	0,64
R410A	1	0,95	0,9	0,85	0,81	0,77	0,73	0,7	0,67	0,64

When subcooling ahead of the expansion valve is other than 4 °C , adjust the evaporator capacity by dividing by the appropriate correction factor found in Table 9.

www.castel.it



ed. 001-VE-ENG

Castel can accept no responsibility for any errors or changes in the catalogues, handbooks, brochures and other printed material. Castel reserves the right to make changes and improvements to its products without notice. All trademarks mentioned are the property of their respective owners. The name and Castel logotype are registered trademarks of Castel Srl. All rights reserved.

Castel Srl - Via Provinciale 2-4 - 20060 Pessano con Bornago - MI