

Rev No.	Alteration	Date	Checked	Approved
12	ADDED DEBURR & MATERIAL INFO	2009/07/27	AP	PDM

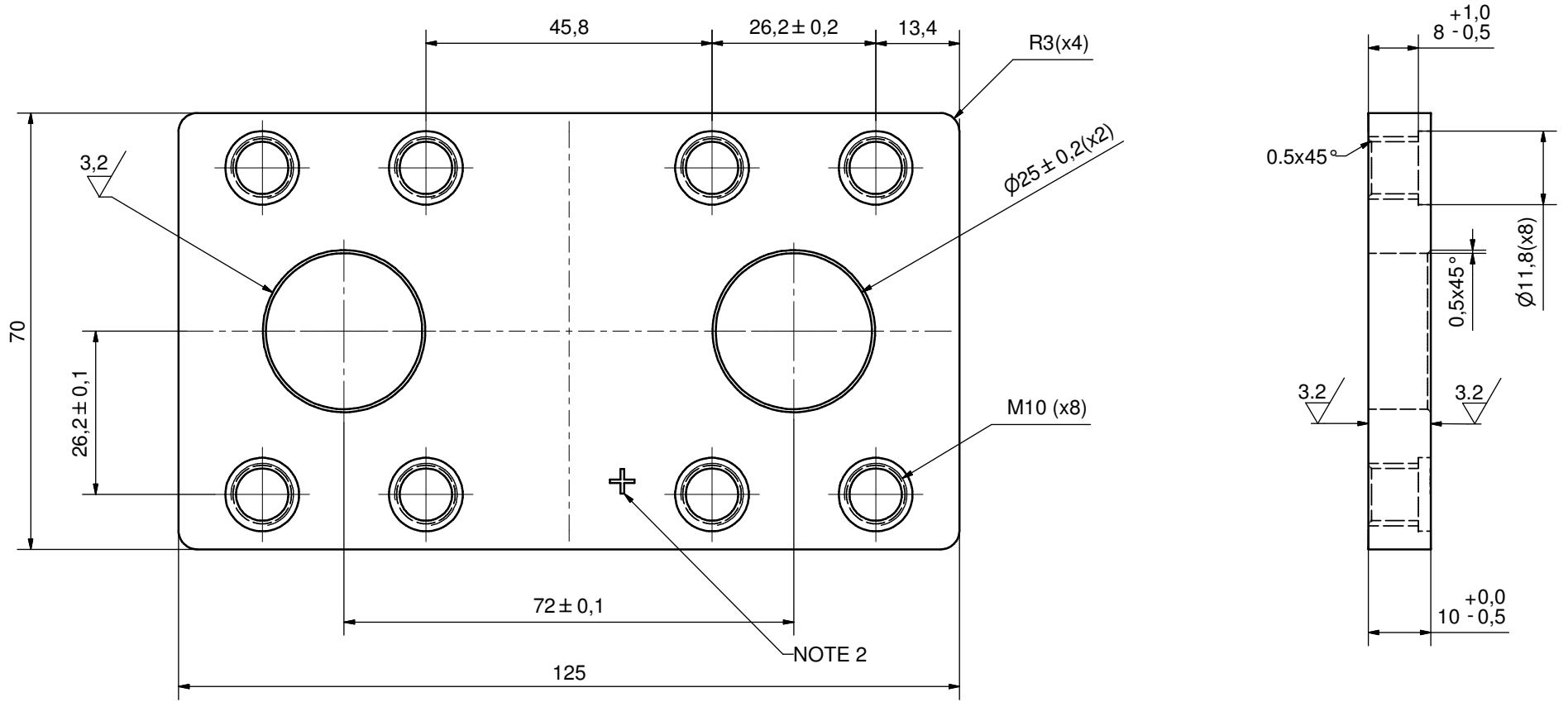

NOTE 2: MARKING FOR IDENTIFICATION OF BACKSIDE.

NOTE 1: OUTER SURFACE IS NOT INCLUDED IN SURFACE TOLERANCE

HOLE PATTERN OF CONNECTIONPLATES CONFORMS TO SAE 1'' FLANGES.

ALL EDGES DEBURRED

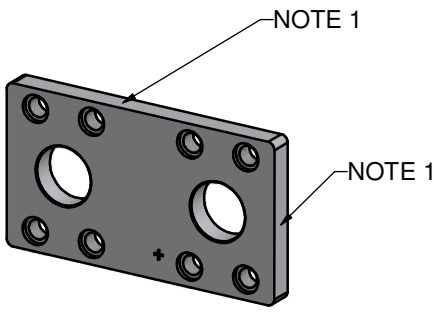

FLATNESS	GAUGE LENGHT
0,1	100
0,15	IN ALL

DEBURR SHARP EDGES; MAX 0,4

ACCORDING TO MQS MATERIAL

Drawn	Checked	Approved	Created Date	General geometrical tolerancing ISO 2768	General surface finish R_a	Scale
JA	STA	ToD	1998-10-07	m	3,2	-

SUPER

Article number: - Title: **CONN. PLATE 2xSAE 1''**

Drawing number: **CD000392** Revision: 12 Sheet: 1 (1)

DOVER COMPANY